



ServoOne

Operation Manual

Single-Axis System

4 A to 450 A



ServoOne Drives with Ambition

The modular design of ServoOne ensures optimal integration into the machine process. Whether through a high speed field bus communication with the central multi-axis machine control, or through decentralized programmable Motion Control Intelligence in the drive controller, ServoOne will master both tasks brilliantly.

ServoOne Operation Manual Single-Axis System

Id.-No.: 1100.20B.6-00

Status: 09/2011

Valid from firmware status: V2.20-01

The German version is the original version of the operation manual.

Technical alterations reserved

The contents of our documentation have been compiled with greatest care and in compliance with our present status of information.



Nevertheless we would like to point out that this document cannot always be updated parallel to the technical further development of our products.

Information and specifications may be changed at any time. For information on the latest version please refer to <http://drives.lt-i.com>.

Guide through this document

Dear user!

We are happy that you have made a decision in favour of a product from LTI DRIVES. In order to be able to start operation of your new ServoOne quickly and without problems, we ask you kindly to read this operation manual thoroughly beforehand,

Step	Action	Comment
 1.	This Operation Manual will enable you to install and commission ServoOne drive system very quickly and easily.	Guide to quick-starting
 2.	Simply follow the step-by-step tables in the chapters.	And away you go!

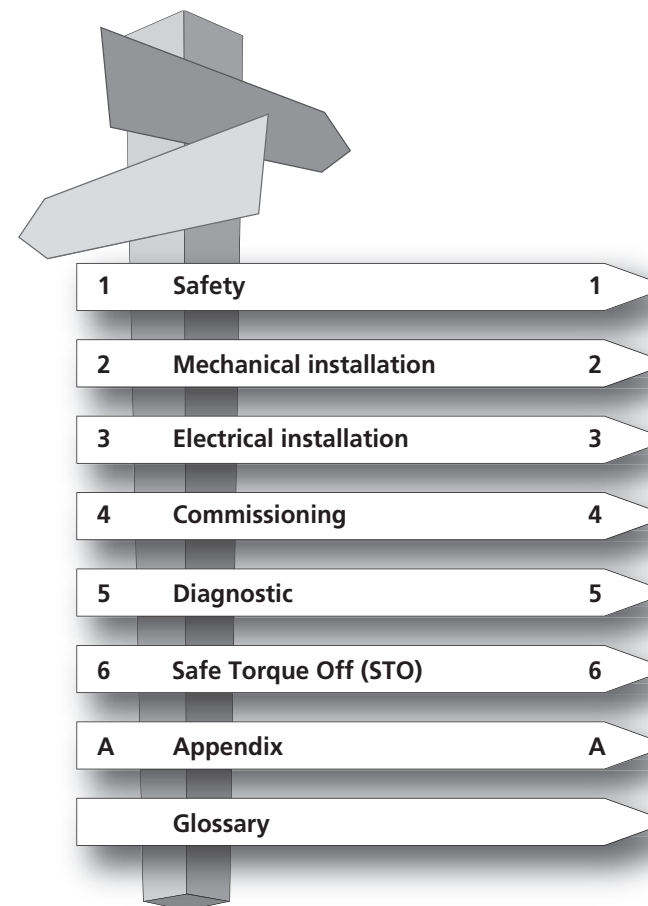

Order Code

The order designation SO8x.xxx.0xxx.xxxx.x informs you about the corresponding variant of the drive controller delivered to you. The significance of the individual characters of the order designation is given in the following order code. You will find a complete order code with all values in the ServoOne system catalogue.

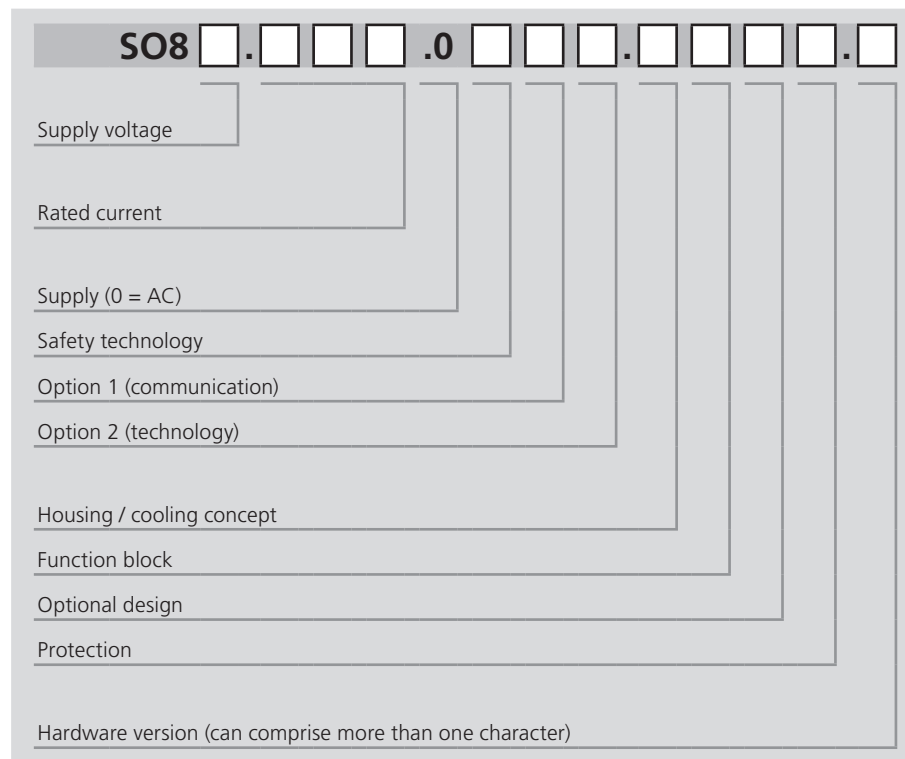

Fig 0.1 Order code ServoOne Single-Axis System

Rating plate

The rating plate on ServoOne drive units informs about the serial number, from which you can read the manufacturing date by using the following key. The location of the rating plate on your ServoOne can be found from page 18 onwards.

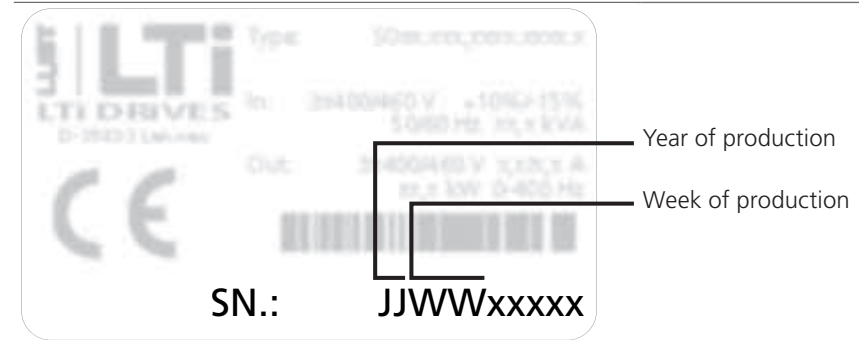

Fig 0.2 Rating plate hardware ServoOne Single-Axis System

Scope of supply

The scope of supply includes:

- ServoOne drive unit
- Terminal accessory pack for control and power terminals (depending on device rated power and variant)
- Set of grommets (on devices with liquid cooling)
- Product DVD

Pictograms

Pictograms as described in the following table are used in this operation manual for better orientation. The meaning of the corresponding pictogram is always correct, even if it is placed e.g. next to a terminal diagram without any accompanying text.





Warning symbols (see also section 1.1)	
	ATTENTION! Misoperation may cause damage to or malfunction of the drive.
	DANGER CAUSED BY HIGH VOLTAGE! Improper behaviour may cause danger to human life.
	DANGER FROM ROTATING PARTS! The drive may automatically start to run.
Notes & supportive action	
	NOTE: useful information or reference to other documents
	STEP: Processing step within a multi-action sequence

Table of Contents

1	Safety	9
1.1	Measures for your safety	9
1.2	Intended use	10
1.3	Responsibility	10
2	Mechanical installation	11
2.1	Notes on installation	11
2.2	Installation	11
2.2.1	Dimensions on devices with air cooling	12
2.2.2	Dimensions on devices with liquid cooling	14
2.2.3	Connection of cooling circuit	16
3	Installation	17
3.1	Notes for installation	17
3.2	Overview of connections BG1 to BG4	18
3.3	Overview of connections BG5 to BG6a	20
3.4	Overview of connections BG7	22
3.5	Connection PE conductor	24
3.6	Electrical isolation concept	24
3.7	Connection of supply voltages	26
3.7.1	Connection control supply (24 V DC)	26
3.7.2	Connection of AC mains supply	27
3.7.3	Use with mains choke	29
3.7.4	Use with internal mains filter	29
3.7.5	Use with external mains filter	29
3.7.6	Terminal diagram precharge (only BG7)	30
3.8	Control connections	30
3.8.1	Specification of control connections	31
3.8.2	Brake driver	32
3.9	Specification USB interface	33
3.10	Specification Ethernet interface	33
3.11	Option 1	33
3.12	Option 2	33
3.13	Encoder connection	33
3.13.1	Encoder connection on LSH/T-motors	34
3.13.2	Assignment of motor/encoder cable to drive controller	34
3.13.3	Ready made-up encoder cables	34
3.13.4	Resolver connection	35
3.13.5	Connection for high resolution encoders	35
3.14	Motor connection	36
3.14.1	Motor connection on LSH/LST-motors	37
3.14.2	Ready made-up motor cable	37
3.14.3	Switching in the motor cable	38
3.15	Braking resistor (RB)	38
3.15.1	Protection in case of a brake chopper fault	38
3.15.2	Design with integrated braking resistor BG1-4	39
3.15.3	Design with integrated braking resistor BG5-7	39
3.15.4	Connection of an external braking resistor	40
4	Commissioning	41
4.1	Notes for operation	41
4.2	Initial commissioning	41
4.2.1	Switching on control supply	42
4.2.2	Connection between PC and drive controller	42
4.2.3	Parameter setting	42
4.2.4	Drive control with DriveManager 5	42

4.3	Serial commissioning.....	44	A.2	Technical data ServoOne.....	62
4.4	Integrated control unit and MMC-card.....	45	A.2.1	SO82.004 to SO84.016, air cooling.....	62
4.4.1	Function of buttons T1 and T2.....	46	A.2.2	SO84.020 to SO84.072, air cooling.....	63
4.4.2	Display.....	46	A.2.3	SO84.090 to SO84.170, air cooling.....	64
4.4.3	Parameter menu (PA).....	47	A.2.4	SO84.016 to SO84.060, liquid cooling.....	65
4.4.4	Ethernet IP-address menu (IP).....	48	A.2.5	SO84.072 to SO84.210, liquid cooling.....	66
4.4.5	Field bus address menu (Fb).....	49	A.2.6	SO84.250 to SO84.450, liquid cooling.....	67
4.4.6	Firmware update with MMC-card.....	50	A.3	Connections for motor cable.....	68
5	Diagnosis.....	51	A.4	Current demand of control supply.....	68
5.1	Status display on device.....	51	A.5	Ambient conditions.....	68
5.1.1	Device states.....	51	A.6	Mains filter.....	70
5.1.2	Error display.....	51	A.7	Hydrological data for the liquid cooling.....	71
5.2	Status and error displays in DM5.....	52	A.8	Dynamic monitoring of the heat sink temperature.....	71
5.3	Helpline/Support & Service.....	54	A.9	UL-approbation.....	71
6	Safe Torque Off (STO).....	55	Glossary.....		73
A	Appendix.....	57			
A.1	Permissible current load for drive controllers.....	57			
A.1.1	Current carrying capacity BG1, air cooling, single-phase.....	57			
A.1.2	Current carrying capacity BG1-BG4, air cooling, triple-phase.....	57			
A.1.3	Current carrying capacity BG5-BG6a, air cooling.....	58			
A.1.4	Current carrying capacity BG3-BG4, liquid cooling.....	60			
A.1.5	Current carrying capacity BG5-BG6a, liquid cooling.....	60			
A.1.6	Current carrying capacity BG7, liquid cooling.....	61			

1 Safety

1.1 Measures for your safety

The following information must be read before initial commissioning to avoid physical injury and/or material damage. The safety regulations must be strictly observed at any time.





	<p>Read the Operation Manual first!</p> <ul style="list-style-type: none"> • Follow the safety instructions! • Please observe the user information!
	<p>Electric drives are generally potential danger sources:</p> <ul style="list-style-type: none"> • Electrical voltages 230 V AC to 680 V DC Even 30 minutes after switching off the mains supply dangerously high voltages of ≥ 50 V may still be present (capacitor charge). Therefore check for isolation from supply! • Rotating parts • Hot surfaces
	<p>Protection against magnetic and/or electromagnetic fields during installation and operation.</p> <ul style="list-style-type: none"> • For persons with pacemakers, metal containing implants and hearing aids etc. access to the following areas is prohibited: <ul style="list-style-type: none"> – Areas in which drive systems are installed, repaired and operated. – Areas in which motors are assembled, repaired and operated. Motors with permanent magnets are sources of special dangers. <p>NOTE: If there is a necessity to access such areas a decision from a physician is required.</p>
	<p>Your qualification:</p> <ul style="list-style-type: none"> • In order to prevent personal injury or material damage, only personnel with electrical engineering qualifications may work on the device. • The qualified person must become familiar with the operation manual (see IEC 364, DIN VDE 0100). • Knowledge of national accident prevention regulations (e.g. BGV A3 in Germany)
	<p>During installation follow these instructions:</p> <ul style="list-style-type: none"> • Always comply with the connection conditions and technical specification. • Comply with the standards for electrical installation, such as wire cross-section, PE-conductor and ground connection. • Do not touch electronic components and contacts (electrostatic discharge may destroy components).

Table 1.1 Notes on safety

Warning symbols used

The notes on safety describe the following danger classes.

The danger class describes the risk which may arise when not complying with the corresponding safety note.

Warning symbols	General explanation	Danger class acc. to ANSI Z 535
	ATTENTION! Misoperation may cause damage to or malfunction of the drive.	This may result in physical injury or damage to material.
	DANGER CAUSED BY HIGH VOLTAGE! Improper behaviour may cause danger to human life.	Danger to life or severe physical injury.
	DANGER FROM ROTATING PARTS! The drive may automatically start to run.	Danger to life or severe physical injury.

Table 1.2 Explanation of warning symbols

1.2 Intended use

ServoOne drive controllers are components for installation into stationary electric, industrial and commercial systems or machines.

When installed in machines commissioning of the drive controller (i.e. start-up of intended operation) is prohibited, unless it has been ascertained that the machine fully complies with the regulations of the machine directive 2006/42/EC; compliance with EN 60204 is mandatory.

Commissioning, i.e. starting intended operation, is only permitted when strictly complying with the EMC-directive (2004/108/EC).



The ServoOne DC-Axis Controller is in conformity with the low voltage directive 2006/95/EC.

The axis controller fulfils the demands of the harmonized product standard EN 61800-5-1.

If the drive controller is used in special applications, e.g. in potentially explosive areas, the applicable regulations and standards (e.g. in potentially explosive areas EN 50014 "General provisions" and EN 50018 "Flameproof enclosure") must strictly be followed.

Repairs must only be carried out by authorised repair workshops. unauthorised opening and incorrect intervention could lead to physical injury or material damage. The warranty granted by LTI DRIVES will become null and void.



NOTE: The use of drive controllers in mobile equipment is assumed an exceptional environmental condition and is only permitted after a special agreement.

1.3 Responsibility

Electronic devices are never fail-safe. The company setting up and/or operating the machine or plant is itself responsible for ensuring that the drive is rendered safe if the device fails.

The standard EN 60204-1/DIN VDE 0113 "Safety of machines", under the subject "Electrical equipment of machines", stipulates safety requirements for electrical controls. They are intended for the safety of personnel and machinery as well as for maintaining the functional capability of the machine or plant concerned, and must be observed.

The function of an emergency stop system does not necessarily cut the power supply to the drive. To protect against danger, it may be more beneficial to keep individual drives running or to initiate specific safety sequences. Execution of the emergency stop measure is assessed by means of a risk analysis of the machine or plant, including the electrical equipment in accordance with EN ISO 14121 (previously DIN EN 1050), and is determined by selecting the circuit category in accordance with EN ISO 13849-1 (previously DIN EN 954-1) "Safety of machines - Safety-related parts of controls".

2 Mechanical installation

2.1 Notes on installation



ATTENTION!

- **During installation work**

Strictly avoid that ...

- drill chips, screws or other foreign objects drop into the device
- moisture enters into the device

- **Control cabinet**

The device is solely intended for installation in a stationary control cabinet. The control cabinet must at least meet the requirements of degree of protection IP4x. When using the safety function STO (Safe Torque OFF), the control cabinet must, in accordance with EN ISO 13849-2, have a degree of protection of IP54 or higher.

- **Environment**

- The drive controllers must not be installed in areas where they would be permanently exposed to vibrations. Further information can be found in table A.18 in the appendix.
- The device heats up during operation and the temperature on the heat sink may reach 100 °C. Please bear this in mind for adjacent components.

The following general guidelines apply for the installation of single axis controllers:

- **Cooling**

Cooling air must be able to flow through the device without restriction. For installation in control cabinets with convection (= heat loss is discharged to the outside via the cabinet walls), always fit an internal air circulation fan.

- **EMC compatible installation**

The best result for an EMC compatible installation is achieved by using a well grounded, chromated or galvanised mounting plate. If mounting plates are paint coated, remove the coating from the contact area! The devices themselves have an aluminium back panel (BG1 to BG2) or a back panel made of aluminized/ galvanized sheet steel (BG5 to BG7).

- **Pollution severity**

Maximum pollution severity 2 in accordance with EN 60664-1. Further information on environmental conditions can be found in table A.16 in the appendix.

If you require further detailed information on installation you should consult the LTI Helpline (see page 54).

2.2 Installation

Step	Action	Comment
1.	Mark out the positions of the tapped holes and, if applicable, the pipe socket on the mounting plate. Drill the holes and cut a thread for each fastening screw into the mounting plate.	Observe the mounting clearances! Consider the bending radius of the connecting leads! Dimensioned drawings/hole distances see Fig. 2.2 to Fig. 2.5
2.	Mount the drive controller vertically on the mounting plate.	Observe the mounting clearances! The contact area must be metallic bright.
3.	For devices with liquid cooling the pipe sockets must be supported with a 22 mm open end spanner when screwing in the hose connections (not included in the scope of supply), to prevent the device from being damaged by torsional torque.	Ensure perfect liquid tight connection (e.g. use Teflon sealing tape)!
4.	Install further components, such as e.g. mains filter, power choke, etc. on the mounting plate.	The lead between mains filter and drive controller must not be longer than max. 30 cm.
5.	Now continue with the electrical installation in chapter 3.	

Table 2.1 Mechanical installation



NOTE: Connect the liquid cooling supply at BG7 to the marked connection (Fig. 2.5). For BG3 to BG6a this connection is freely selectable.

2.2.1 Dimensions on devices with air cooling

ServoOne	BG1	BG2	BG3	BG4	BG5	BG6	BG6a
	S082.004 S084.004 S084.006	S084.008 S084.012	S084.016 S084.020	S084.024 S084.032	S084.045 S084.060 S084.072	S084.090 S084.110	S084.143 S084.170
Weight [kg]	3.4	4.9	6.5	7.5	13	28	32
B (Width)	58.5	90	130	171	190	280	
H (Height) ¹⁾	295			345		540	
T (Depth) ¹⁾	224			240		322	
A	29.25	50	80	120	150	200	
C	344.5			365		581	
C1	5			6		10	
D Ø	4.8			5.6		9.5	
Screws	2 x M4	4 x M4		4 x M5		4 x M8	
E	2			20		40	
F ²⁾	≥100		≥150		≥180		
G ²⁾	≥270			≥300		≥500	
H1	355			382.5		600	
H2	38.5			15		20	

all measurements in mm

1) without terminals, plugs and plate screens

2) Possibly bigger bending radii of connecting leads must be accounted for.

Table 2.2 Dimensions of housing with air cooling, see Fig. 2.1 and Fig. 2.2



NOTE: The minimum distance "E" specified in the table for sizes 1-4 applies for devices with the same power. When butt mounting devices with different drive power you should arrange the devices according to their power (e.g. viewed from the left BG4-BG3-BG2-BG1). This minimizes the thermal influence among each other.

When butt mounting ServoOne controllers together with other devices, you must make sure that these device do not affect one another thermally.

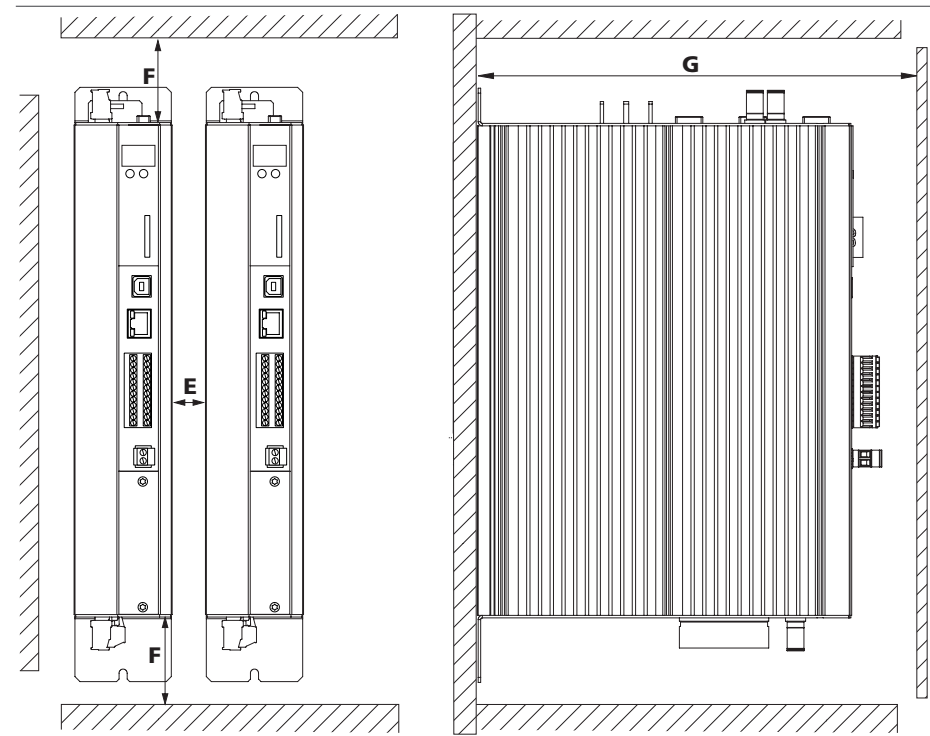

Fig. 2.1 Installation distances in case of air cooling, schematic representation for BG1 to BG6a

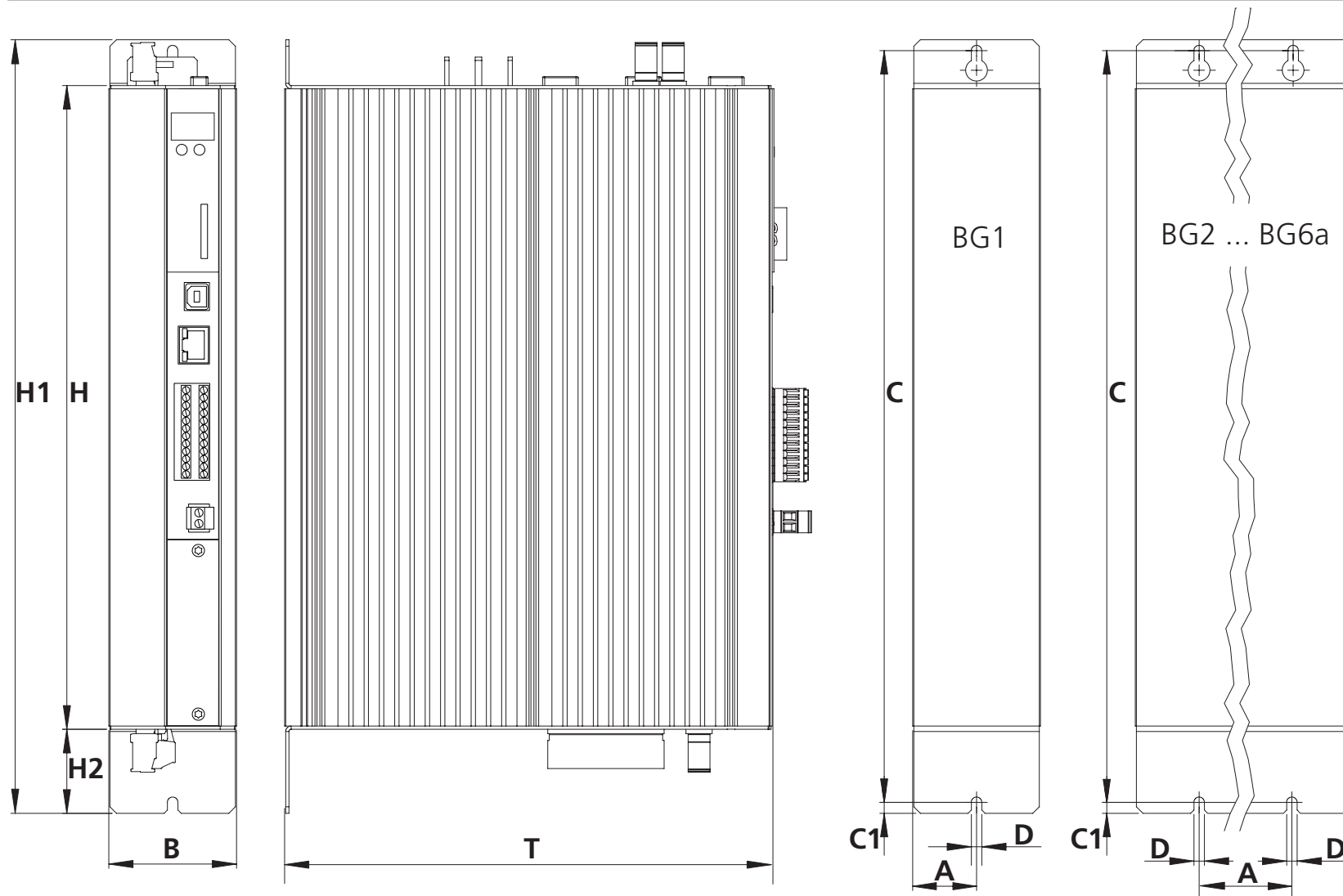

Fig. 2.2 Dimensional drawing of housing with air cooling, schematic representation for BG1 to BG6a

2.2.2 Dimensions on devices with liquid cooling

ServoOne	BG3	BG4	BG5	BG6	BG6a	BG7
	SO84.016 SO84.020	SO84.024 SO84.032	SO84.045 SO84.060 SO84.072	SO84.090 SO84.110	SO84.143 SO84.170	SO84.250 SO84.325 SO84.450
Weight [kg]	6.5	7.5	16.5	31.5	41.1	100
B (Width)	130	171	190	280		380
H (Height) ¹⁾	295		345	540		952
T (Depth) ¹⁾	224		198.3	202	282	286.5
A	80	120	148	200		150
A1	10	25	39	65		29
A2	60	70				
C	382		377.25	581		952
C1	5		8	10		12
H1	392		394.25	600		971/1305 ³⁾
H2	38.5		16.75	20		60
H3	75	70	53.75	56.5		136
T1	74		73.5			
D Ø	4.8		7	9.5		12
Screws	4 x M4		4 x M6	4 x M8		6 x M10
S	3/8 inch (female thread)					
D1 Ø	48 (bore for pipe socket)					
E	2					
F ²⁾	≥150		≥180			
G ²⁾	≥270		≥300		≥500	

all measurements in mm

1) without terminals, plugs and plate screens

2) Possibly bigger bending radii of connecting leads must be accounted for.

3) without/with terminal covers and plate screens

Table 2.3 Dimensions of housing with liquid cooling, see Fig. 2.3 to Fig. 2.5



NOTE: The minimum distance "E" specified in the table applies for devices with the same power. When butt mounting devices with different drive power you should arrange the devices according to their power (e.g. viewed from the left BG4-BG3-BG2-BG1). This minimizes the thermal influence among each other.

When butt mounting ServoOne controllers together with other devices, you must make sure that these device do not affect one another thermally.

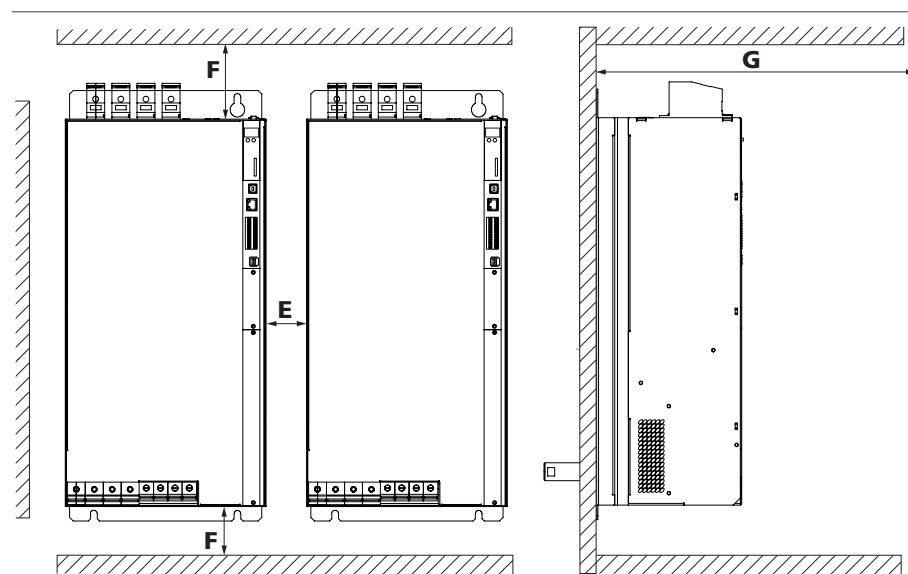

Fig. 2.3 Installation distances in case of liquid cooling, schematic representation for BG3 to BG7

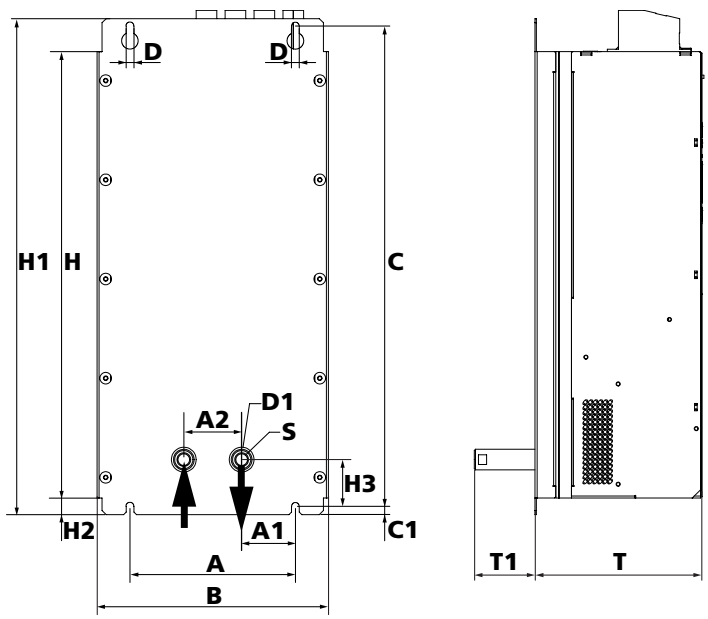

Fig. 2.4 Dimensional drawing of housing with liquid cooling, schematic representation for BG3 to BG6a

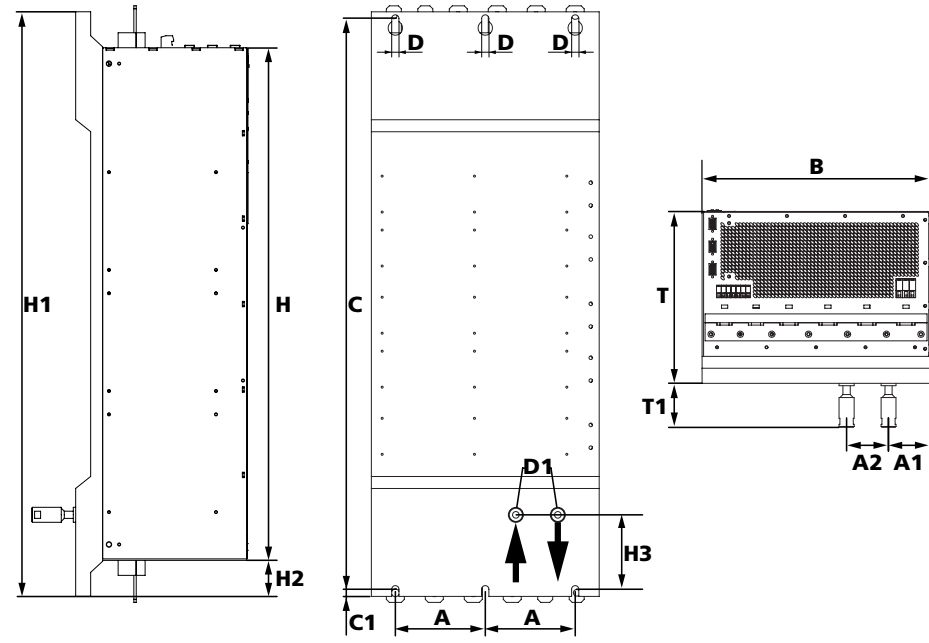
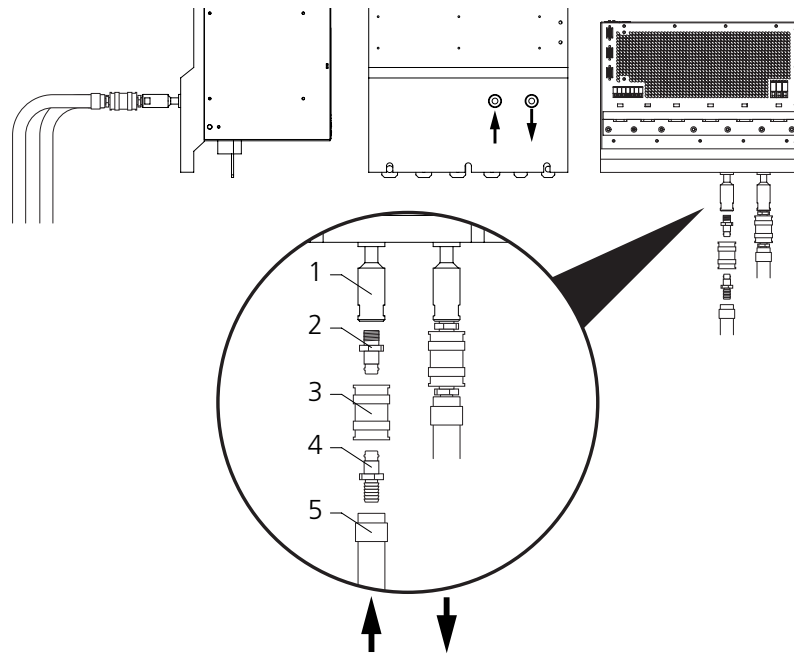

Fig. 2.5 Dimensional drawing of housing with liquid cooling, schematic representation for BG7

2.2.3 Connection of cooling circuit

Depending on size the ServoOne has a liquid coolant capacity of up to 0.5 l. After disconnecting the connections residual liquid may remain in the device and run out when tipped over. We recommend to use a drip free liquid coupling (not included in the scope of supply), to prevent liquid coolant from running out and to enable disconnecting and connecting in filled condition.



Legend

- 1) Liquid connection with 3/8 inch female thread
- 2) Drip free quick-release nipple with 3/8 inch male thread
- 3) Drip free liquid coupling
- 4) Adapter for hose connection
- 5) PuR (polyurethane) hose with hose clamp

Fig. 2.6 Connection of cooling circuit (here: BG7)



NOTES:

- **Scope of supply**

Positions 2 to 5 are **not** contained in the scope of supply and must be provided by the customer.

- **Supply connection**

Connect the supply of the liquid cooling strictly to the connections marked in Fig. 2.4, Fig. 2.5 or Fig. 2.6 accordingly.

3 Installation

3.1 Notes for installation



ATTENTION!

- **Qualified personnel**

Installation must only be carried out by electrical engineering experts who have been specially instructed in the necessary accident prevention measures.

- **During installation work**

Strictly avoid that ...

- screws, cable rests or foreign bodies drop into the device
- moisture enters into the device



DANGER CAUSED BY HIGH VOLTAGE!

- **Danger to life!**

- Never wire or disconnect electrical connections while they are live. Isolate the device from the mains supply (230/400/460/480 V AC) before working on it. Even 30 minutes after switching off the mains supply dangerously high voltages of ≥ 50 V may still be present (capacitor charge). Work on the device must only be carried out, after the DC link voltage has dropped below a residual voltage of 50 V (on BG1-BG4 to be measured on terminals X12/L- and L+ or on BG5 to BG6a on terminals X12/ZK- and X12/ZK+, on BG/ on terminals X11/ZK- and X11/ZK+).
- Dangerous voltage may be applied to the device, even if the device does not emit any visual or audible signals/indications (e.g. with mains voltage applied to terminal X11) and missing control supply (+24 V on X9/X10 or X44)!

The following general guidelines apply for the installation of single axis controllers:

- **Compliance with the EMC product standard**

Commissioning (i.e. starting intended operation) is only permitted when strictly complying with EMC product standard EN 61800-3:2004. The installer/operator

of a machine and/or equipment must provide evidence of the compliance with the protection targets stipulated in the EMC-standard.

- **Cable type**

- Use only shielded mains, motor and signal lines with double copper braiding that is overlapping by 60 to 70 %.
- If very large cable cross-sections need to be routed, shielded individual cores may be used instead of shielded cables.

- **Routing of cables**

- Route mains, motor and signal cables separated from one another. If possible, keep a distance of at least 0.2 m, otherwise use separators.
- Always route the motor cable without interruptions and the shortest way out of the control cabinet. When using a motor contactor or a motor choke, the respective component should be directly mounted to the drive controller and the shielding of the motor cable should not be stripped off too soon.
- If possible enter signal lines only from one side into the control cabinet.
- Lines of the same electric circuit must be twisted.
- Avoid unnecessary cable lengths and loops.

- **Grounding**

Grounding measures of relevance for the drive controller are described in section 3.5 "Connection PE conductor" on page 24.

- **Shielding measures**

Do not strip the cable shields too early and attach them amply to both the component and the PE bar (main ground) of the mounting plate.

- **External components**

- Place larger consumers near the supply.
- Contactors, relays, solenoid valves (switched inductivities) must be wired with fuses. The wiring must be directly connected to the respective coil.
- Any switched inductance should be at least 0.2 m away from the process controlled assemblies.

Additional information can be found in the corresponding connection description. If you require further detailed information on installation you should consult the LTI Helpline (see page 54).

Step	Action	Comment
1.	Determine the pin assignment for your device.	Section 3.2 for BG1 to BG4 Section 3.3 for BG5 to BG6a Section 3.4 for BG7
2.	Connect all required input and output units to the control terminals and, if necessary, to the options.	Section 3.8 Section 3.11 and/or 3.12
3.	Connect encoder, motor and, if necessary, the external braking resistor.	Sections 3.13, 3.14 and 3.15
4.	Connect the PE-conductor and the supply voltages.	Sections 3.5 and 3.7
5.	Continue with the commissioning in chapter 4.	

Table 3.1 Electrical installation

3.2 Overview of connections BG1 to BG4

The following shows the layout with the corresponding positions of plugs and terminals. For better orientation we have identified the designations of plugs and terminals with an abbreviation.

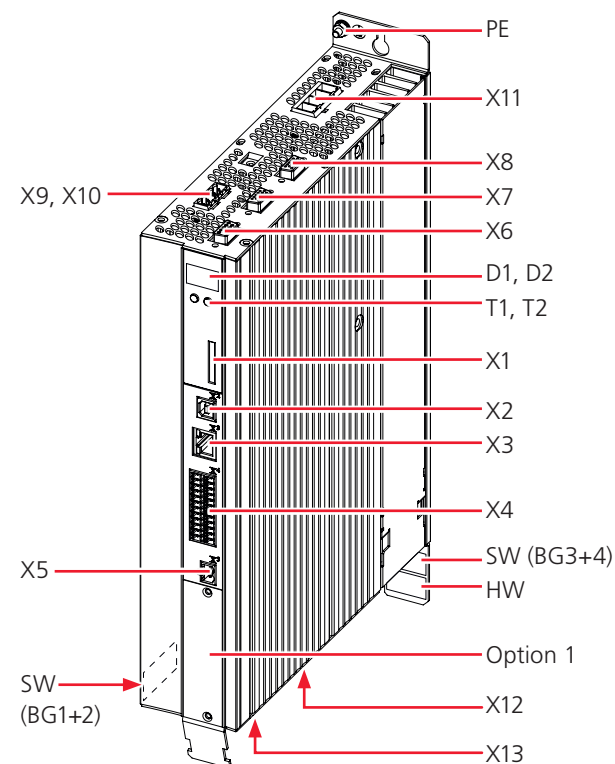

Fig. 3.1 Layout BG1 to BG4 (here: BG1)

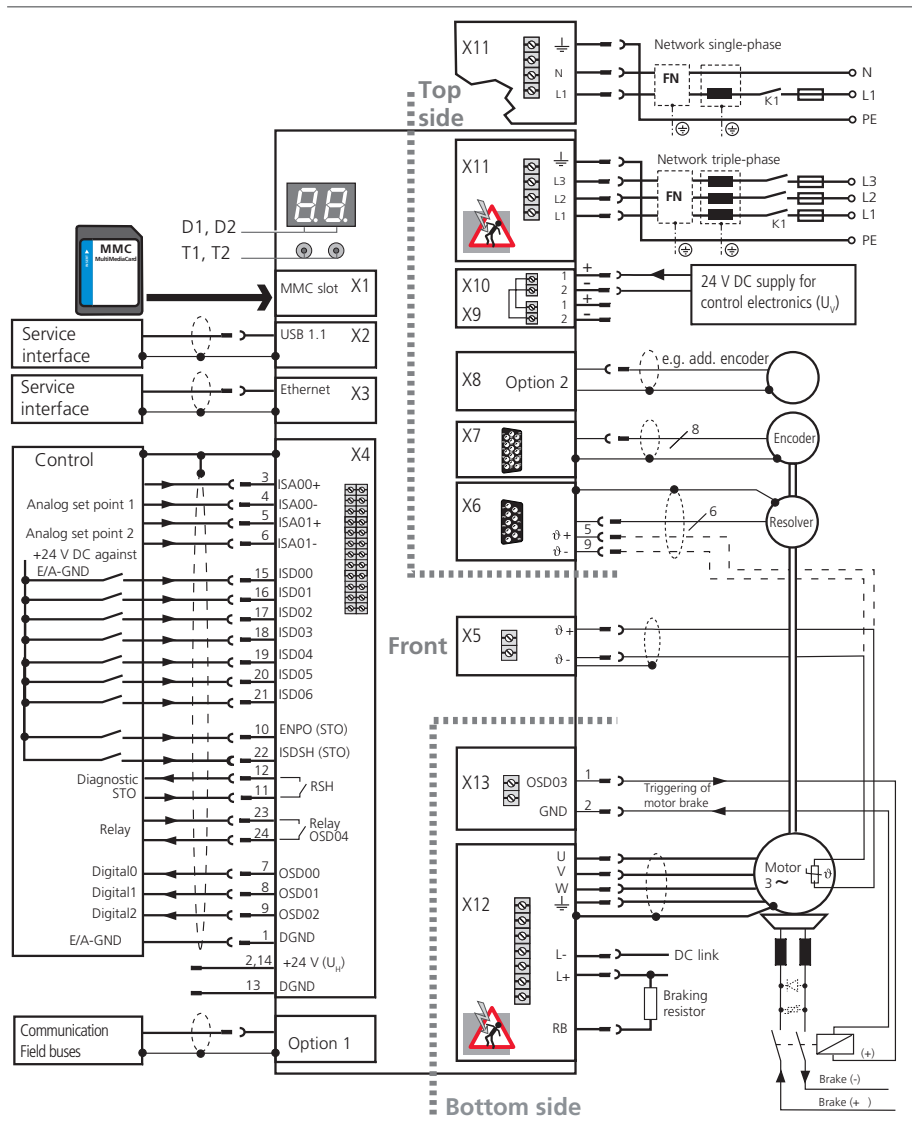

Fig. 3.2 Terminal diagram BG1 to BG4

Number	Designation	Details
D1, D2	7-segment display	page 46
T1, T2	Button	page 46
X1	Slot for MMC-card	page 45
X2	USB 1.1 interface	page 33
X3	Ethernet interface	page 33
X4	Control terminals	page 30
Option 1	Communication	page 33
X11	Connection AC power supply	page 27
PE	Connection PE conductor	page 24
X9, X10	Connection control supply	page 26
X8 (Option 2)	Technology	page 33
X7	Connection high resolution encoder	page 35
X6	Connection resolver	page 35
X5	Connection motor temperature monitoring	page 36
X13	Connection motor brake	page 32
X12	Connection motor, braking resistor and DC link	page 36
HW	Hardware rating plate	page 4
SW	Software rating plate	-

Table 3.2 Legend to terminal diagram BG1 to BG4

3.3 Overview of connections BG5 to BG6a

The following shows the layout with the corresponding positions of plugs and terminals. For better orientation we have identified the designations of plugs and terminals with an abbreviation.

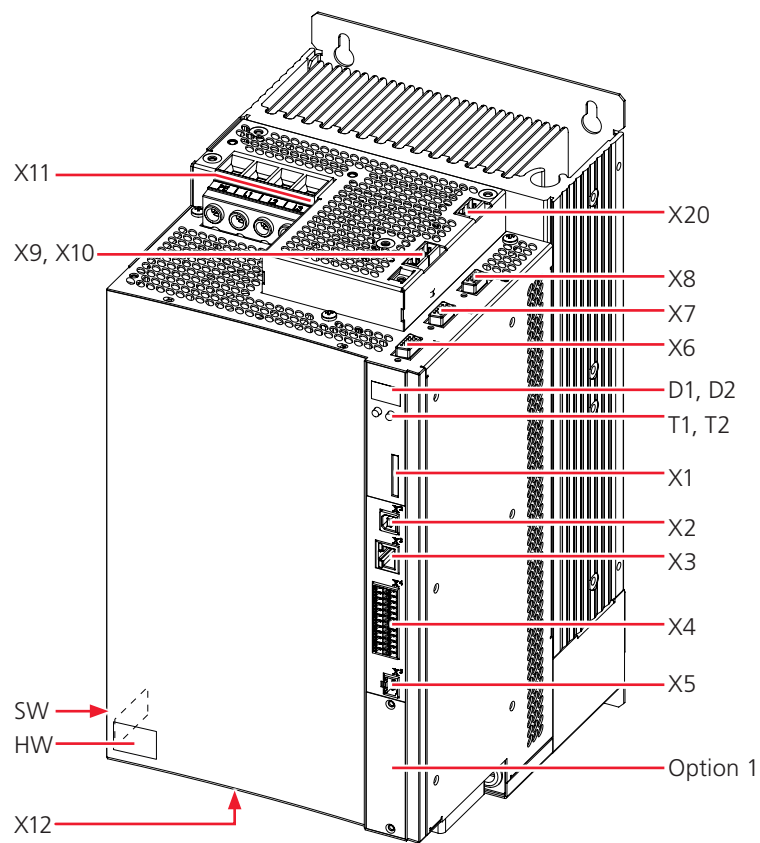

Fig. 3.3 Layout BG5 (here: Housing variant for wall mounting)

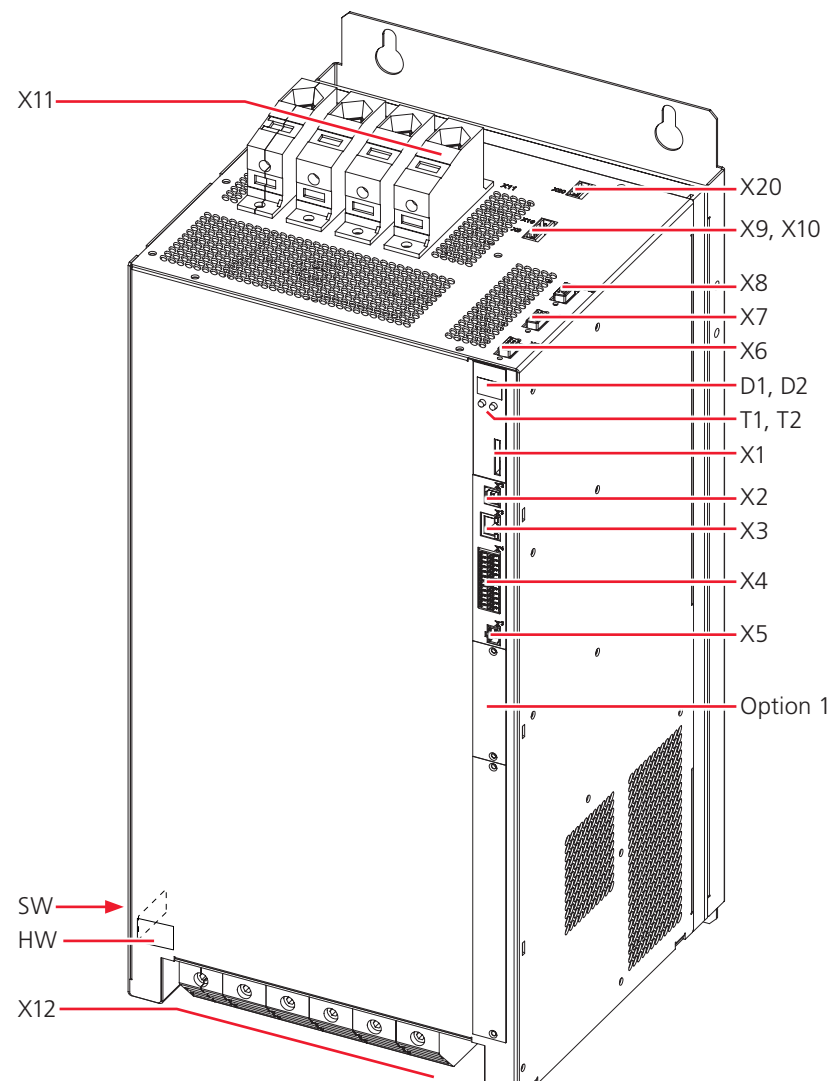

Fig. 3.4 Layout BG6 and BG6a (here: BG6a, housing variant liquid cooling)

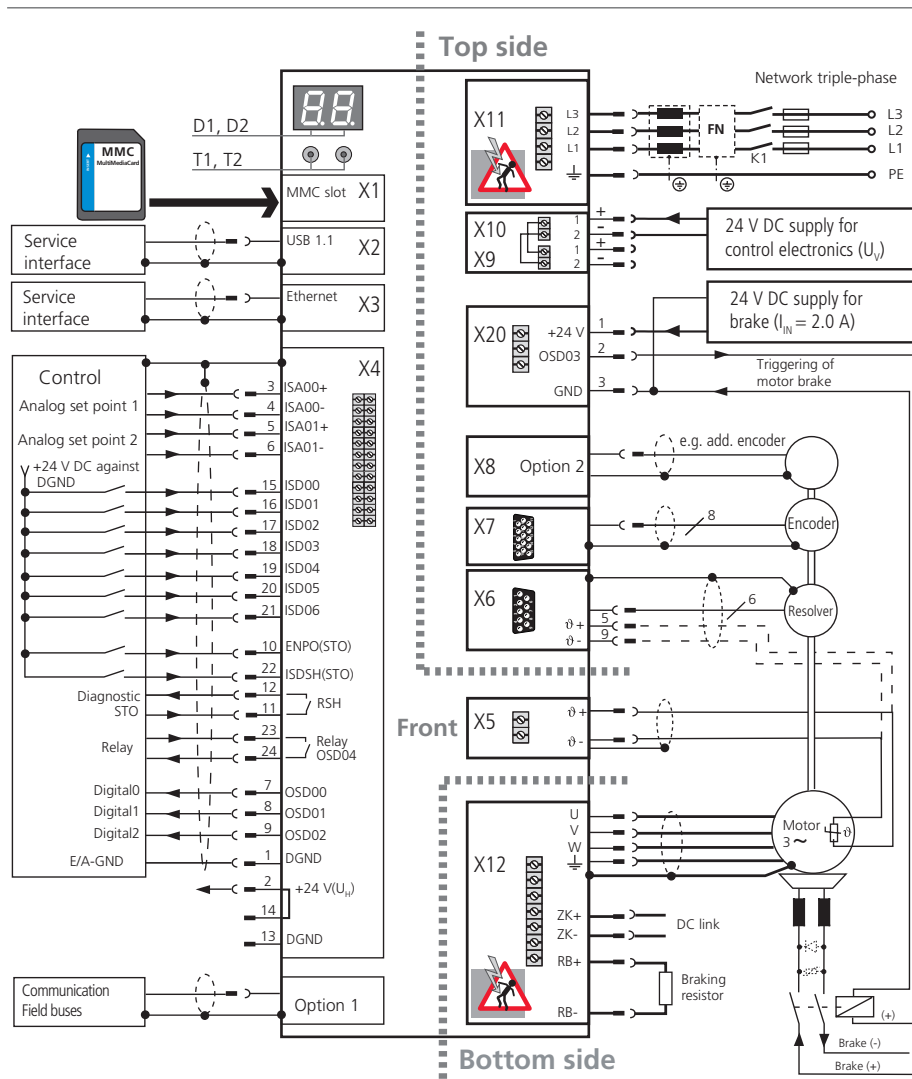

Fig. 3.5 Terminal diagram BG5 to BG6a

Number	Designation	Details
D1, D2	7-segment display	page 46
T1, T2	Button	page 46
X1	Slot for MMC-card	page 45
X2	USB 1.1 interface	page 33
X3	Ethernet interface	page 33
X4	Control terminals	page 30
Option 1	Communication	page 33
X11	Connection AC power supply	page 27
PE	Connection PE conductor	page 24
X9, X10	Connection control supply	page 26
X20	Connection motor brake	page 32
X8 (Option 2)	Technology	page 33
X7	Connection high resolution encoder	page 35
X6	Connection resolver	page 35
X5	Connection motor brake	page 36
X12	Connection motor, braking resistor and DC link	page 36
HW	Hardware rating plate	page 4
SW	Software rating plate	-

Table 3.3 Legend to terminal diagram BG5 to BG6a

3.4 Overview of connections BG7

The following shows the layout with the corresponding positions of plugs and terminals. For better orientation we have identified the designations of plugs and terminals with an abbreviation.

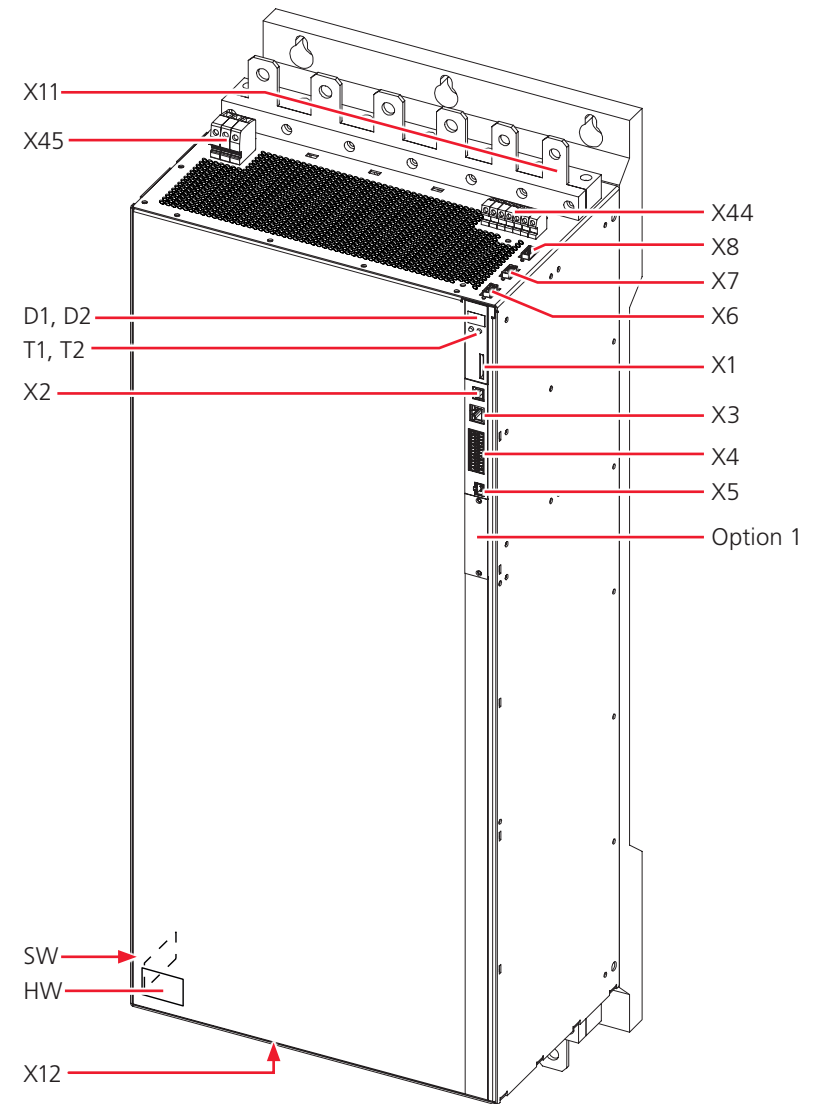

Fig. 3.6 Layout BG7 (here without plate screens and terminal covers on X11 and X12)

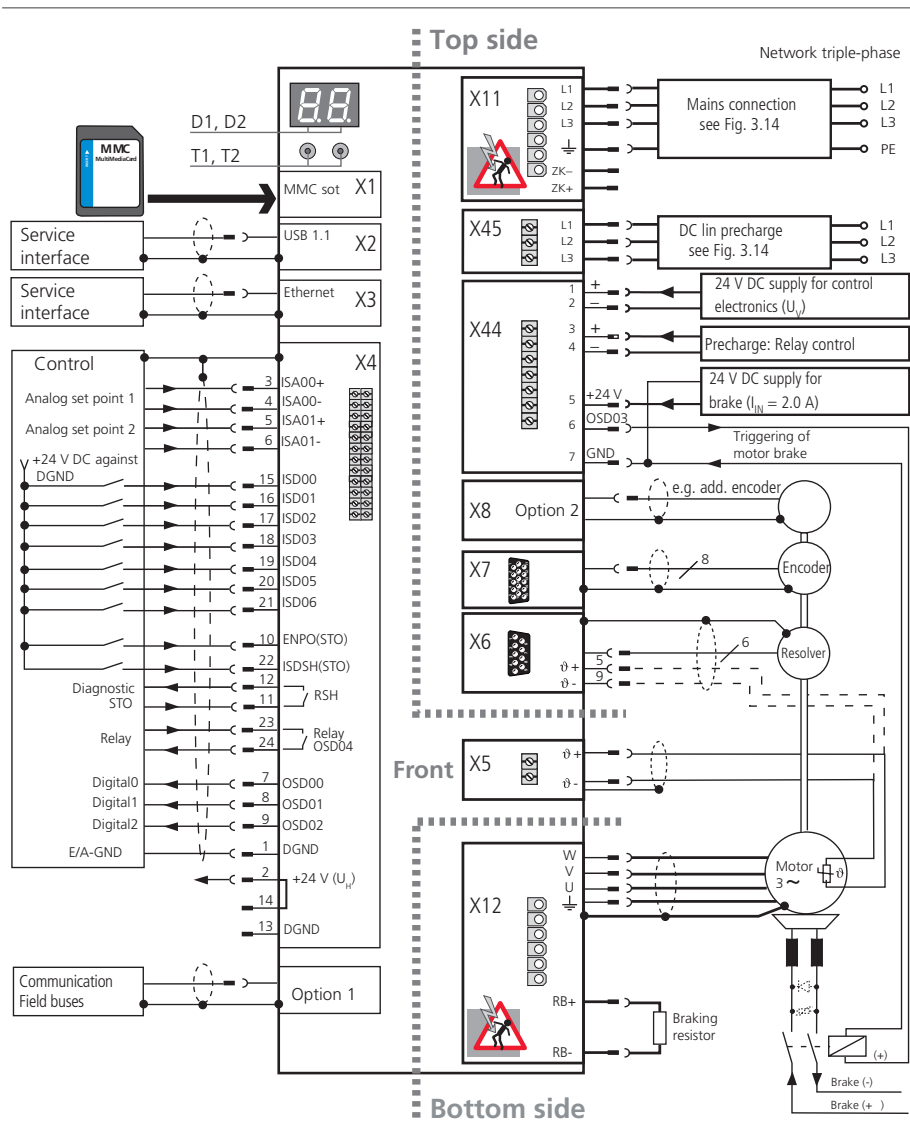

Fig. 3.7 Terminal diagram BG7

Number	Designation	Details
D1, D2	7-segment display	page 46
T1, T2	Button	page 46
X1	Slot for MMC-card	page 45
X2	USB 1.1 interface	page 33
X3	Ethernet interface	page 33
X4	Control terminals	page 30
Option 1	Communication	page 33
X11	Connection AC power supply and DC link	page 27
PE	Connection PE conductor	page 24
X45	Connection DC link pre-charging	page 30
X44	Connection control supply, pre-charging circuit and motor brake	page 26
X8 (Option 2)	Technology	page 33
X7	Connection high resolution encoder	page 35
X6	Connection resolver	page 35
X5	Connection motor temperature monitoring	page 36
X12	Connection motor, braking resistor	page 36
HW	Hardware rating plate	page 4
SW	Software rating plate	-

Table 3.4 Legend to terminal diagram BG7

3.5 Connection PE conductor

Step	Action	PE mains connection acc. DIN EN 61800-5-1
1.	Ground each of the drive controllers! Connect terminal \oplus in star configuration and amply dimensioned with the PE bar (main ground) in the control cabinet.	The following applies for the PE connection (because leakage current > 3.5 mA): • Mains connection <10 mm ² copper: use PE-conductor cross-section min. 10 mm ² copper or two cables with the cross-section of the mains cables.
2.	Also connect the PE-conductor terminals of all other components, such as mains choke, filter, etc. in a star configuration and amply dimensioned with the PE bar (main ground) in the control cabinet.	• Mains connection ≥10 mm ² copper: use a PE-conductor cross section complying with the cross-section of the mains cables. Apart from this, you must also consider local and country specific regulations and conditions.

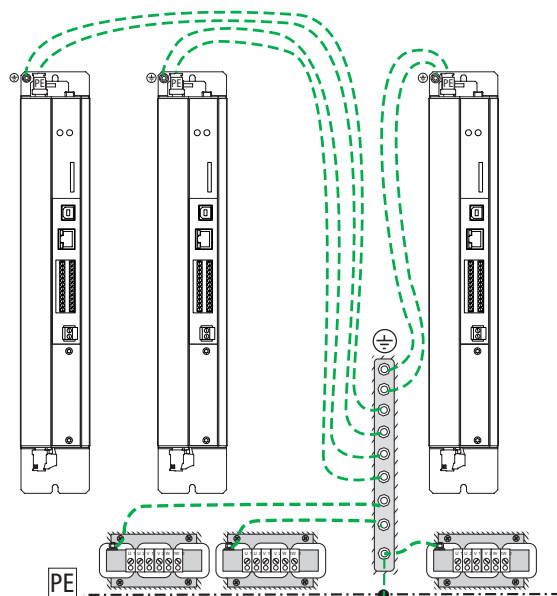

Fig. 3.8 Star configuration layout of PE conductor

3.6 Electrical isolation concept

The control electronics with its logics (μ P), the encoder terminals and the inputs and outputs is galvanically isolated from the power section (mains supply/DC link). All control terminals are designed as safety extra-low voltage (SELV/PELV) circuit and must only be operated with SELV or PELV voltages complying with the corresponding specification. This provides reliable protection against electric shock on the control side.

You therefore need a separate control supply, compliant with SELV/PELV requirements.

The opposite overview shows the potential supplies for the individual terminals in detail. This concept additionally enhances the operational safety and reliability of the drive controller.



ATTENTION! Terminal X5 (motor PTC) represents a special feature with respect to insulation and isolation. In this respect follow the notes in section 3.14 "Motor connection" from page 36.

SELV = Safety Extra Low Voltage

PELV = Protective Extra Low Voltage

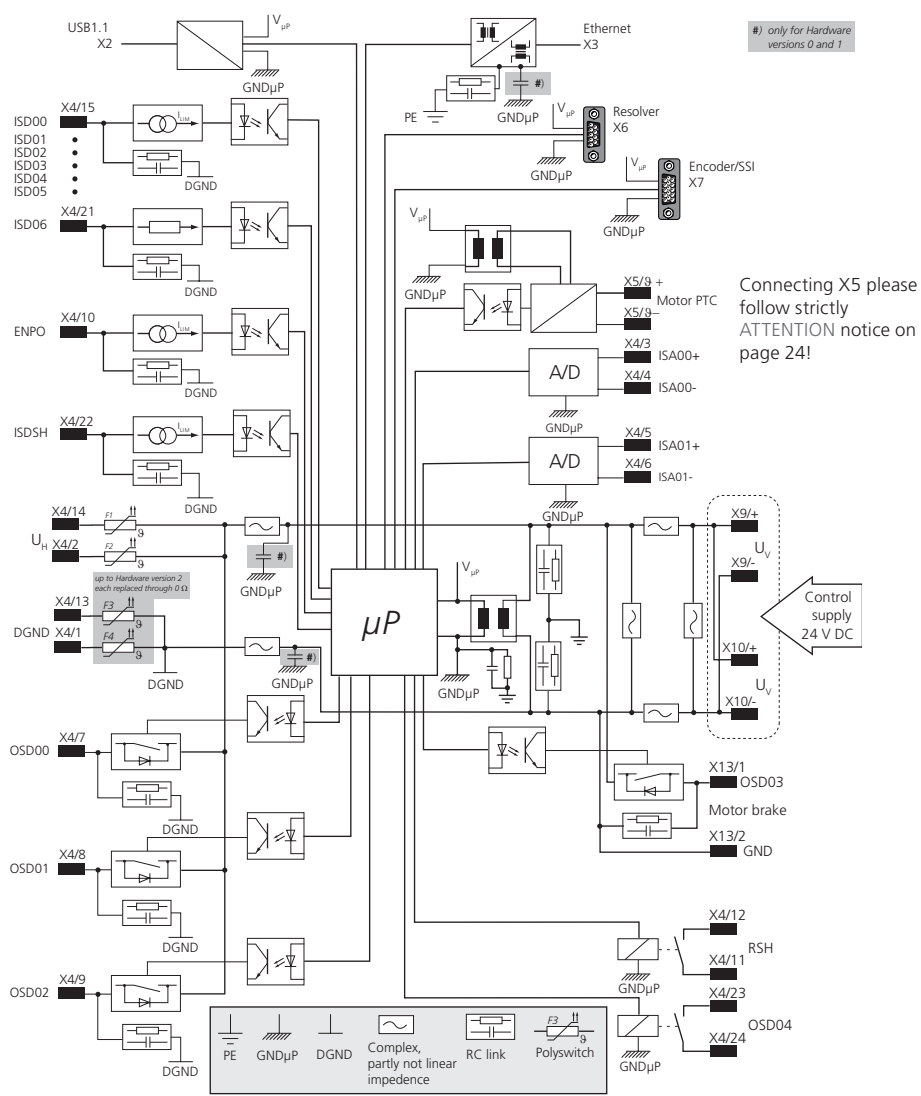

Fig. 3.9 Electrical isolation concept for BG1 to BG4

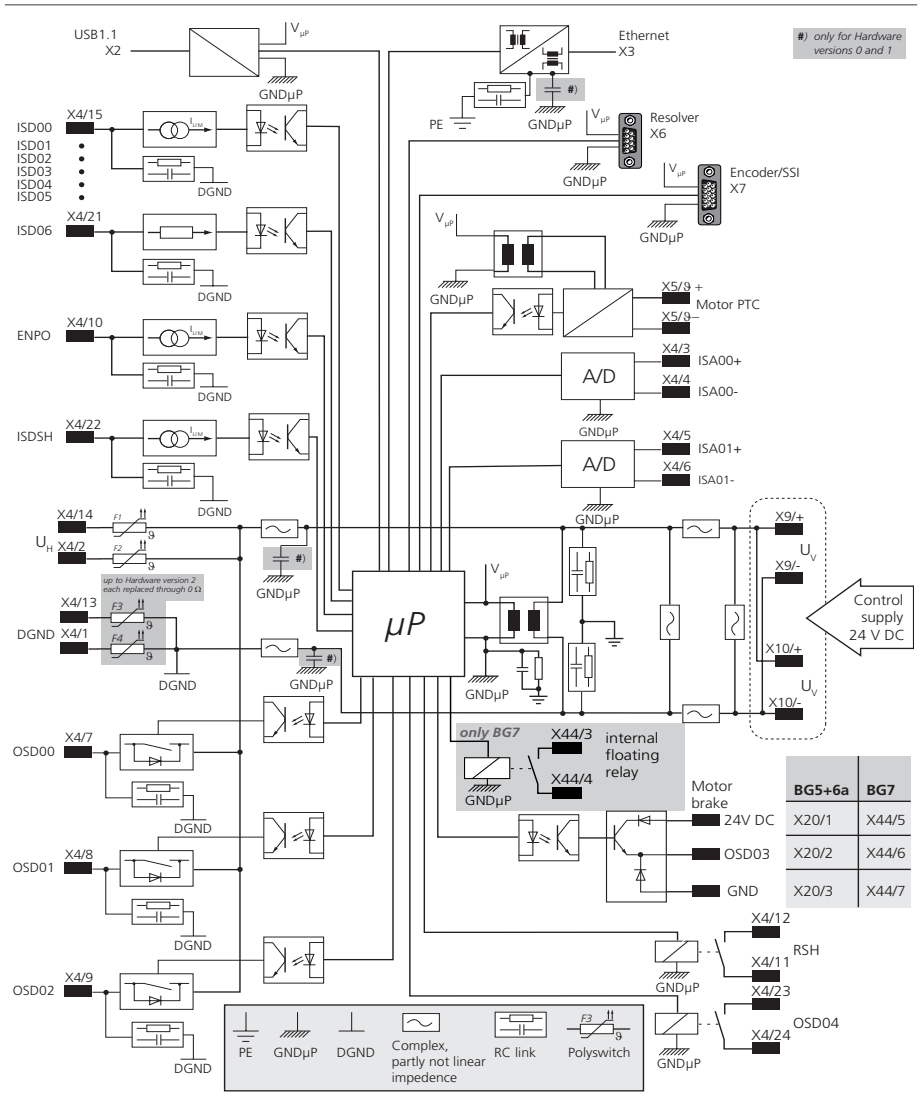

Fig. 3.10 Electrical isolation concept BG5 to BG7

3.7 Connection of supply voltages

The power supply for the ServoOne is separated into the supplies for control and power sections. In the connecting sequence the control supply must always be connected **first**, so that triggering of the ServoOne can first be checked or the device can be parameterized for the intended application.



DANGER CAUSED BY HIGH VOLTAGE: Dangerous voltage may be applied to the device, even if the device does not emit any visual or audible signals/indications (e.g. with mains voltage applied to terminal X11 and missing control supply (+24 V DC on X9/X10 or X44)!

3.7.1 Connection control supply (24 V DC)

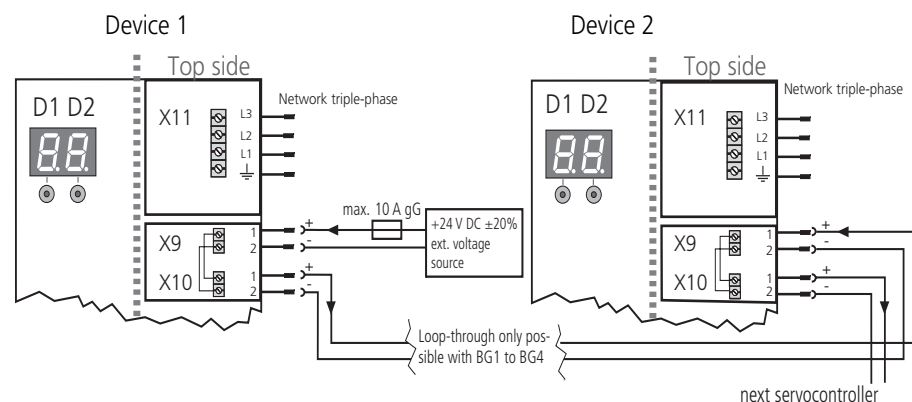

Fig. 3.11 Connection control supply BG1 to BG6a



NOTE: The connection of control supply for BG7 can be found in Fig. 3.14 on page 29.



ATTENTION! Generally apply suitable measures to provide adequate line protection.

Control supply BG1 to BG6a

Terminal/Pin	Specification
X9/1 = + X9/2 = -	<ul style="list-style-type: none"> • $U_v = 24 \text{ V DC } \pm 20\%$ (BG5 to BG6a +20/-10%), stabilized and filtered • max. starting and continuous currents see table A.15 on page 68. • Current carrying capacity of terminal continuously max. 10 A (BG5 to BG6a max. 8 A), internal polarity reversal protection • The power supply unit used must have a safe and reliable isolation towards the mains network, as per EN 50178 or EN 61800-5-1. • Internally interconnected with X10
X10/1 = + X10/2 = -	<ul style="list-style-type: none"> • Current carrying capacity of terminal continuously max. 10 A (BG5 to BG6a max. 8 A) • Internally interconnected with X9

Table 3.5 Specification control supply BG1 to BG6a







NOTE: With sizes BG1 to BG4 the external voltage source not only supplies the control unit, but also the output for the motor holding brake. If this output is active, the current for the control unit plus the current for the motor holding brake and additional current requirements for digital inputs and outputs flows through terminal X9. Please take this into consideration when rating the voltage source for the control unit and when looping through to other equipment. The current demand for the individual devices can be found in the appendix on page 68 in table A.15.

Control supply BG7

Terminal/Pin	Specification
X44/1 = + X44/2 = -	<ul style="list-style-type: none"> • $U_v = 24 \text{ V DC } \pm 10\%$, stabilized and filtered • max. starting and continuous currents see table A.15 on page 68 • Current carrying capacity of terminal continuously max. 10 A, internal polarity reversal protection • The power supply unit used must have a safe and reliable isolation towards the mains network, as per EN 50178 or EN 61800-5-1.

Table 3.6 Specification control supply BG7

3.7.2 Connection of AC mains supply

Step	Action	Comments
 1.	Determine the cable cross-section, depending on maximum current and ambient temperature.	Cable cross-section acc. to local and country specific regulations and conditions.
 2.	Wire the drive controller according to its size and type of connection. For cable lengths in excess of 0.3 m use shielded cables!	see Fig. 3.12, Fig. 3.13 or Fig. 3.14
 3.	If necessary wire the mains choke, see section 3.7.2	Reduces the voltage distortions (THD) in the net and prolongs the lifetime of the drive controller.
 4.	Install a K1 circuit breaker (power circuit breaker, contactor, etc.).	Do not yet switch on the AC mains supply!
 5.	Use mains fuses (duty class gG, see table 3.7), which will isolate all poles of the drive controller from the mains supply.	For compliance with the equipment safety act acc. to EN 61800-5-1



DANGER CAUSED BY HIGH VOLTAGE! Danger to life! Never wire or disconnect electrical connections while these are live. Always isolate the device from the mains supply before working on it. Even 30 minutes after switching off the mains supply dangerously high voltages ≥ 50 V may still be present (capacitor charge). Therefore check for isolation from supply!



ATTENTION! Should local regulations require the installation of a residual current protective device (RCD), the following applies:

In case of a fault the drive controller is able to generate DC fault currents without zero crossing. Drive controllers therefore must only be operated with residual current protective device (RCDs) type B for AC fault currents, pulsating or smooth DC fault currents, which are suitable for drive controller operation, see IEC 60755. Residual current monitoring devices (RCMs) can additionally be used for monitoring purposes.

Please note:

- Switching the mains power:
 - In case of too frequent switching the unit protects itself by high-resistance isolation from the system. After a rest phase of a few minutes the device is again ready for operation.
- TN network and TT network: Operation is permitted if:
 - with single-phase devices for 1 x 230 V AC the supply network corresponds with the maximum overvoltage category III in accordance with EN 61800-5-1.
 - with triple-phase devices with phase-to-phase voltages 3 x 230 V AC, 3 x 400 V AC, 3 x 460 V AC and 3 x 480 V AC
 1. **the neutral point** of the supply net **is grounded** and
 2. the supply net meets the requirements of the maximum 2. overvoltage category III in accordance with EN 61800-5-1 under a system voltage (external conductor → neutral point) of maximum 277 V.
- IT-network: not permitted!
 - In case of an ground fault the electrical stress is approx. twice as high. Clearances and creepages acc. to EN 61800-5-1 are no longer maintained.
- Connection of the drive controller via a mains choke is mandatory:
 - where the drive controller is used in applications with disturbance variables corresponding with environment class 3, as per EN 61000-2-4 and higher (hostile industrial environment).
 - for compliance with EN 61800-3 or IEC 61800-3, see appendix.
- For further information on current carrying capacity, technical data and environmental conditions please refer to the appendix.



NOTE: Please note that the ServoOne has not been designed for environment class 3. Further measures are mandatory in order to achieve this environment class! For further information please consult your project engineer.

Drive controller	Device connected load ¹⁾ [kVA]		Max. cable cross-section ²⁾ of terminal [mm ²]	Specified mains fuse, duty class gG [A]	
	With mains choke (4% u _K)	Without mains choke			
SO82.004	1.6	2.2	4	1 x max. 16	
SO84.004	2.8	4.0	4	3 x max. 10	
SO84.006	4.2	6.0	4	3 x max. 16	
SO84.008	5.9	8.3	4	3 x max. 20	
SO84.012	8.8	12.5	4	3 x max. 25	
SO84.016	11.1	15.0	16	3 x max. 32	
SO84.020	13.9	18.7	16	3 x max. 40	
SO84.024	16.6	22.5	16	3 x max. 50	
SO84.032	22.2	30.0	16	3 x max. 63	
	With mains choke (2% u _K)				
SO84.045	31	<i>For devices of sizes BG5 to BG7 a mains choke is mandatory.</i>	25	3 x max. 63	
SO84.060	42		25	3 x max. 80	
SO84.072	50		25	3 x max. 100	
SO84.090	62		50	3 x max. 125	
SO84.110	76		50	3 x max. 160	
SO84.143	99		95	3 x max. 200	
SO84.170	118		95	3 x max. 224	
SO84.250	173		Connection via screwed on ring terminal ends.		3 x max. 300
SO84.325	225				3 x max. 400
SO84.450	310				3 x max. 500

1) With 3 x 400 V mains voltage

2) The minimum cross-section of the power supply cable depends on local regulations and conditions, as well as on the rated AC current of the drive controller.

Table 3.7 Connected load an mains fuse



NOTE: Before commissioning the value of the connected mains voltage must be set in the drive controller (factory setting = 3 x 400 V AC).

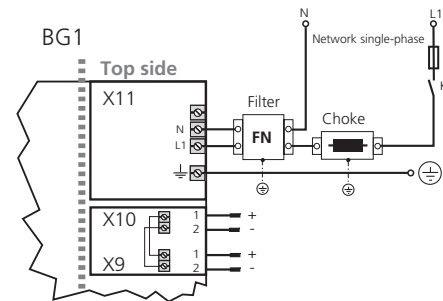

Fig. 3.12 Connection of mains supply 1 x 230 V

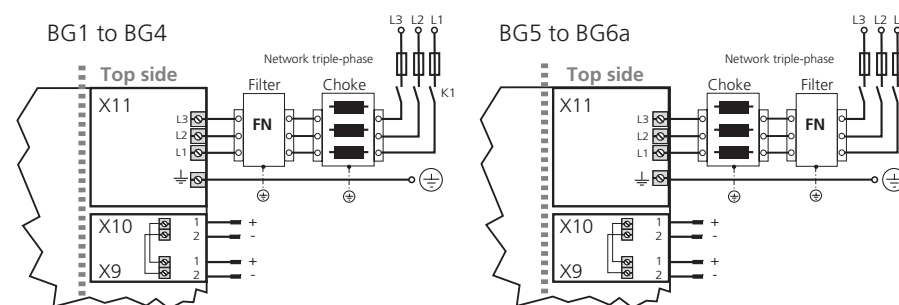

Fig. 3.13 Connection of mains supply 3 x 230/400/460/480 V for BG1 to BG6a



ATTENTION! For devices of sizes BG5 to BG7 a mains choke is mandatory. Due to the different precharging technology in these devices you must make sure that the mains choke is installed between drive controller and mains filter (see Fig. 3.13 and Fig. 3.14).

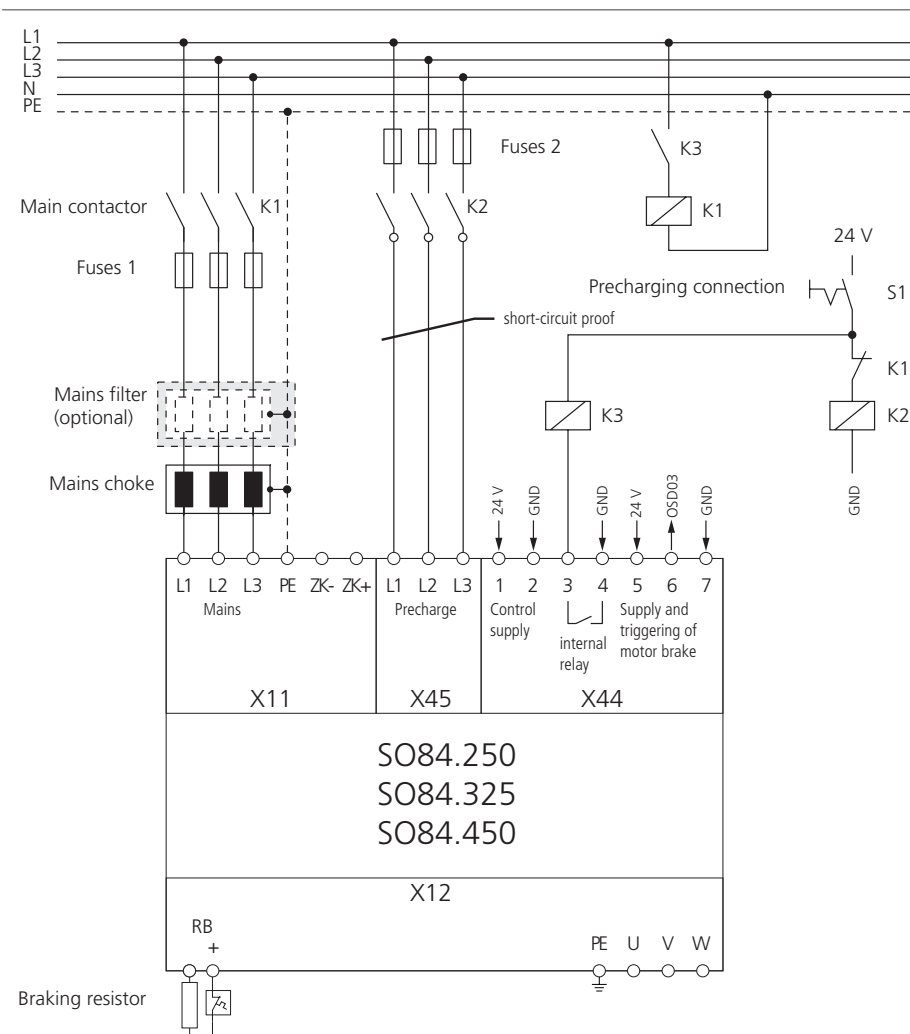

Fig. 3.14 Connection of precharge, control and mains supply 3 x 230/400/460/480 V for BG7 (from serial number 1028xxxx)

3.7.3 Use with mains choke

The use of mains chokes is:

- necessary with all device from and including size BG5
- necessary when using drive controllers in hostile industrial networks
- recommended to prolong the lifetime of DC link capacitors

3.7.4 Use with internal mains filter

Drive controllers BG1 to BG5 are equipped with integrated mains filters. With the measuring methods specified in the standard these drive controllers comply with the EMC safety-related requirements specified in IEC 61800-3 for "Environment 1" (residential area C2) and "Environment 2" (industrial area C3). More detailed information see section A.6 „Mains filter“, page 70.



ATTENTION! This is a restricted availability product in accordance with IEC 61800-3. In living areas this product may cause radio interference; in this case the operator may be forced to apply appropriate measures.

3.7.5 Use with external mains filter

External radio interference suppression filters (EMCxxx) are available for the drive controllers for BG6 and BG6a. With the specified measuring method and the external mains filter these drive controllers also ensure compliance with the EMC product standard EN 61800-3 für "Environment 1" (residential areas C2) and "Environment 2" (industrial area C3).

The question of whether size BG7 requires an external mains filter depends on the type of connection and the local conditions. For this reason the use of a mains filter must always be considered individually and within the scope of a project.

In order to reach the use of longer motor cables and compliance with the EMC product standard IEC 61800-3 for the "general availability" (residential area C1), additional external mains filters are available for the devices with internal mains filters (BG1 to BG5).

3.7.6 Terminal diagram precharge (only BG7)

Designation	Specification		
	SO84.250	SO84.325	SO84.450
Fuses 1	250 A	315 A	400 A
Fuses 2, slow-blowing	6 A		
Mains filter (optional)	220 A	300 A	400 A
Mains choke ($U_k = 2\%$)	250 A	325 A	450 A
K1	225 A / 110 kW / 230 V (e.g. Siemens 3RT10 64-6AP36)	300 A / 160 kW / 230 V (e.g. Siemens 3RT10 66-6AP36)	400 A / 200 kW / 230 V (e.g. Siemens 3RT10 75-6AP36)
K2	12 A / 5.5 kW / 24 V (e.g. Siemens 3RT10 17-1AB01)		
K3	7 A / 3 kW / 24 V (e.g. Siemens 3RT10 15-1AB01)		

Recommended data for operation with asynchronous machine

Table 3.8 Specification of connection periphery

Wire the precharge circuitry as shown in fig. 3.14 as per standard with short-circuit proof cables. The connected loads of the internal relay for terminals X44/3, 4 are $U_{max} = 30$ V DC, $I_{max} = 6$ A. You should therefore use a contactor relay K3.

Control sequence

• Precharge of DC link

Switch S1 "Mains supply On" is switched on. The precharging contactor K2 closes and the DC link is precharged via internal precharging resistor on terminal X45. The main contactor K1 remains open for the time being.

• Precharging completed

At a defined DC link voltage the contact of the internal relay on terminal X44/3.4 is closed. The contactor relay K3 closes and connects the main contactor K1. The precharging contactor K2 is opened via an auxiliary contact (normally closed contact) on K1. The ServoOne changes to standby.

• Switching off

The switch S1 "Mains supply Off" completely disconnects the drive controller from the mains supply.

3.8 Control connections

Step	Action	Comment
1.	Check whether a complete device setting is already available, i.e. whether the drive has already been projected	
2.	If this is the case, a special control terminal assignment applies. Please contact your project engineer to obtain the terminal assignment.	
3.	Choose a terminal assignment.	
4.	Wire the control terminals with shielded cables. The following is strictly required: ISDSH (X4/22) and ENPO (X4/10)	Ground the cable shields over a wide area at both ends. Cable cross-sections: 0.2 to 1.5 mm ² , in case of ferrules with plastic sleeves max. 0.75 mm ²
5.	Keep all contacts still open (inputs inactive)!	
6.	Check all connections once again!	

3.8.1 Specification of control connections

Des.	Terminal	Specification	Electrical isolation																								
Analog inputs																											
ISA0+ ISA0- ISA1+ ISA1-	X4/3 X4/4 X4/5 X4/6	<ul style="list-style-type: none"> $U_{IN} = \pm 10$ V DC Resolution 12 Bit; R_{IN} approx. 101 kΩ Terminal sampling cycle in "IP mode" 125 μs, otherwise 1 ms Tolerance: $U \pm 1\%$ of the measuring range end value 	no																								
Digital inputs																											
ISD00 ISD01 ISD02 ISD03 ISD04	X4/15 X4/16 X4/17 X4/18 X4/19	Standard input <ul style="list-style-type: none"> $U_{INmax} = +24$ V DC +20% I_{max} at 24 V = 3 mA typ. Switching level Low/High: ≤ 4.8 V / ≥ 18 V Frequency range <500 Hz Sampling cycle: 1 ms 	yes																								
ISD05 ISD06	X4/20 X4/21	Touch probe or standard input <ul style="list-style-type: none"> Input for touch probe for quick saving of process data (e.g. actual position) Internal signal delay <table border="1"> <thead> <tr> <th>Hardware version 0..1</th> <th>Min.</th> <th>Max.</th> <th>Typ.</th> </tr> </thead> <tbody> <tr> <td>ISD05</td> <td>3 μs</td> <td>16 μs</td> <td>8 μs</td> </tr> <tr> <td>ISD05</td> <td>4 μs</td> <td>27 μs</td> <td>15 μs</td> </tr> <tr> <td>ISD06</td> <td></td> <td>2 μs</td> <td></td> </tr> </tbody> </table> <table border="1"> <thead> <tr> <th>from Hardware version 2</th> <th>Min.</th> <th>Max.</th> <th>Typ.</th> </tr> </thead> <tbody> <tr> <td>ISD05 + ISD06</td> <td></td> <td>2 μs</td> <td></td> </tr> </tbody> </table> <ul style="list-style-type: none"> Activation via ISD05/ISD06 = 15 (PROBE) Standard input <ul style="list-style-type: none"> Frequency range ≤ 500 Hz Sampling cycle: 1 ms $U_{INmax} = +24$ V DC +20% I_{INmax} at +24 V DC = 10 mA, $R_{IN} =$ approx. 3 kΩ Switching level Low/High: ≤ 4.8 V / ≥ 18 V 	Hardware version 0..1	Min.	Max.	Typ.	ISD05	3 μ s	16 μ s	8 μ s	ISD05	4 μ s	27 μ s	15 μ s	ISD06		2 μ s		from Hardware version 2	Min.	Max.	Typ.	ISD05 + ISD06		2 μ s		yes
		Hardware version 0..1	Min.	Max.	Typ.																						
ISD05	3 μ s	16 μ s	8 μ s																								
ISD05	4 μ s	27 μ s	15 μ s																								
ISD06		2 μ s																									
from Hardware version 2	Min.	Max.	Typ.																								
ISD05 + ISD06		2 μ s																									
ENPO	X4/10	<ul style="list-style-type: none"> Deactivation of the restarting lock (STO) and release of the power stage = High level OSSD-capable (from hardware version 2) Reaction time approx. 10 ms Switching level Low/High: ≤ 4.8 V / ≥ 18 V $U_{INmax} = +24$ V DC +20% I_{IN} at +24 V DC = typ. 3 mA 	yes																								

Table 3.9 Specification of control connections X4

Des.	Terminal	Specification	Electrical isolation
Digital outputs			
OSD00 OSD01 OSD02	X4/7 X4/8 X4/9	<ul style="list-style-type: none"> no destruction in short-circuit incidents (+24 V -> GND), however, device may switch off for a short time. $I_{max} = 50$ mA, PLC-compatible Terminal sampling cycle = 1 ms High-side driver 	yes
STO ("Safe Torque Off")			
ISDSH (STO)	X4/22	<ul style="list-style-type: none"> Request input "STO" = Low level OSSD-capable (from hardware version 2) Switching level Low/High: ≤ 4.8 V / ≥ 18 V $U_{INmax} = +24$ V DC +20% I_{IN} at +24 V DC = typ. 3 mA 	yes
RSH RSH	X4/11 X4/12	Diagnosis STO, both tripping channels active, one normally open with self-resetting circuit breaker (polyswitch) <ul style="list-style-type: none"> 25 V / 200 mA AC, $\cos \varphi = 1$ 30 V / 200 mA DC, $\cos \varphi = 1$ 	yes
Relay output			
REL	X4/23 X4/24	Relay, 1 normally open <ul style="list-style-type: none"> 25 V / 1.0 A AC, $\cos \varphi = 1$ 30 V / 1.0 A DC, $\cos \varphi = 1$ Switching delay approx. 10 ms Cycle time 1 ms 	yes
Auxiliary voltage			
+24 V	X4/2 X4/14	<ul style="list-style-type: none"> Auxiliary voltage to feed the digital inputs $U_H = U_V - \Delta U$ (ΔU typically approx. 1.2 V), no destruction in short-circuit incidents (+24 V -> GND), however, device may switch off for a short time. $I_{max} = 80$ mA (per pin) with self-resetting circuit breaker (polyswitch) 	yes
Digital ground			
DGND	X4/1 X4/13	Reference ground for 24 V, $I_{max} = 80$ mA (per pin), Hardware versions 0..1 with self-resetting circuit breaker (polyswitch)	yes

Table 3.9 Specification of control connections X4



NOTE: High-resistance isolation to device ground
 With too high currents flowing through the ground terminals a high resistance isolation from the device ground is possible. This can lead to malfunction of the drive. To prevent this, you must avoid circulating currents in the wiring.

3.8.2 Brake driver

On BG1 to BG4 plug X13 serves the purpose of connecting a motor brake.

Des.	Terminal	Specification	Connection
OSD03	X13/1	<ul style="list-style-type: none"> Short-circuit proof 	
GND	X13/2	<ul style="list-style-type: none"> Voltage supply through control supply U_V to X9/X10. $U_{BR} = U_V - \Delta U$ (ΔU typically approx. 1.4 V) To trigger a motor brake of up to $I_{BR} = 2.0$ A max., for brakes with higher current requirements a relay must be connected in series. Overcurrent causes shut down Can also be used as configurable digital output. Interruptible cable breakage monitoring <500 mA typically in condition "1" (up to relay) 	

Table 3.10 Specification of terminal connections X13 (BG1 to BG4)

On BG5 to BG6a plug X20 serves the purpose of connecting a motor brake.

Des.	Terminal	Specification	Connection
+24 V	X20/1	<ul style="list-style-type: none"> Short-circuit proof External voltage supply 24 V DC ($I_{IN} = 2.1$ A) required To trigger a motor brake of up to $I_{BR} = 2.0$ A max., for brakes with higher current requirements a relay must be connected in series. Overcurrent causes shut down Interruptible cable breakage monitoring <200 mA typically in condition "1" (up to relay) 	
OSD03	X20/2		
GND	X20/3		

Table 3.11 Specification of terminal connections X20 (BG5 to BG6a)

On BG7 plug X44 serves the purpose of connecting a motor brake.

Des.	Terminal	Specification	Connection
+24 V	X44/5	<ul style="list-style-type: none"> Short-circuit proof External voltage supply 24 V DC ($I_{IN} = 2.1$ A) required To trigger a motor brake of up to $I_{BR} = 2.0$ A max., max., for brakes with higher current requirements a relay must be connected in series. Overcurrent causes shut down Interruptible cable breakage monitoring <200 mA typically in condition "1" (up to relay). 	
OSD03	X44/6		
GND	X44/7		

Table 3.12 Specification of terminal connections X44 (BG7)

3.9 Specification USB interface

The service and diagnostics interface X2 has been realized as USB V1.1-interface. It is solely intended for connecting a PC for commissioning, service and diagnostics with the software DriveManager 5.

Technical specification:

- USB 1.1 standard - full speed device interface
- Connection via conventional USB-interface cable type A to type B (see also ServoOne System Catalogue)

3.10 Specification Ethernet interface

The service and diagnostics interface X3 has been realized as Ethernet interface. It is solely intended for connecting a PC for commissioning, service and diagnostics with the software DriveManager 5.

Technical specification:

- Transfer rate 10/100 Mbits/s BASE-T
- Line protocol IEEE802.3 compliant
- Connection via conventional Crosslink cable (see also ServoOne System Catalogue)

3.11 Option 1

Depending on the ServoOne design variant, option 1 is provided with various options ex-factory. Field bus options like e.g. EtherCAT or SERCOS are available.

All available options can be found in the ServoOne system catalogue. The user manual for the respective option contains detailed information on commissioning.

3.12 Option 2

Option 2 can be fitted with various technological options in the factory. As an example, additional or special encoders can be evaluated.

All available options can be found in the ServoOne system catalogue. The user manual for the respective option contains detailed information on commissioning.

3.13 Encoder connection

All encoder connections are located on the top of the unit.

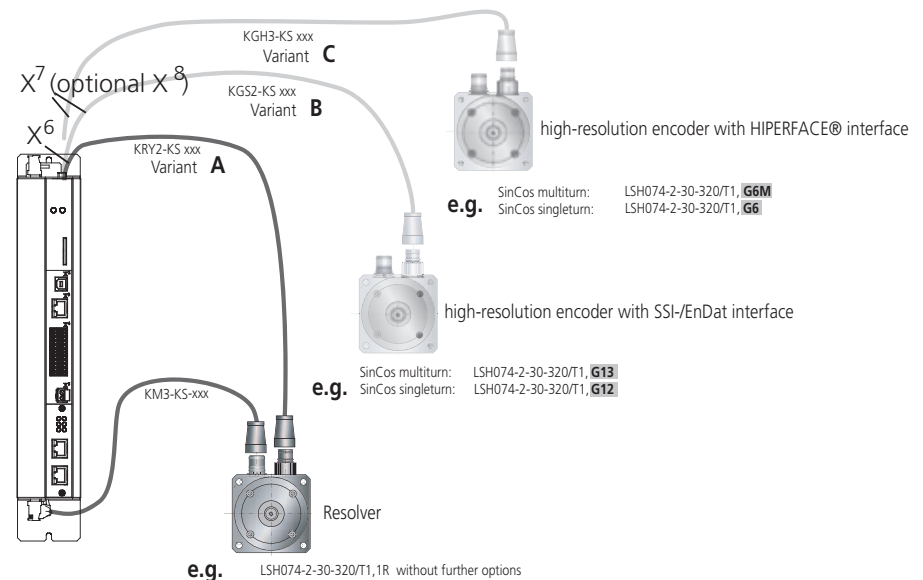

Fig. 3.15 Assignment motor/encoder cable

3.13.1 Encoder connection on LSH/T-motors

For connecting the LSH/T synchronous motors please use the ready made-up motor and encoder cables from LTI DRIVES GmbH.

3.13.2 Assignment of motor/encoder cable to drive controller

Compare the type plates on the components. Make absolutely sure to use the correct components according to a variant A, B or C!

	Motor (with integrated encoder)	Encoder cable	Connection of drive controller
Variant A	with resolver e.g. LSH/LST H074-2-30-320/T1, 1R without further options	KRY2-KSxxx	X6
Variant B	G13: = SinCos multiturn encoder with SSI/EnDat interface e.g. LSH/LST H074-2-30-320/T1,G13	KGS2-KSxxx	X7
	G12: = SinCos singleturn encoder with SSI/EnDat interface e.g. LSH/LST H074-2-30-320T1,G12	KGS2-KSxxx	X7
Variant C	G6: = SinCos singleturn encoder with HIPERFACE® interface e.g. LSH/LST H074-2-30-320/T1,G6	KGH3-KSxxx	X7
	G6M: = SinCos multiturn encoder with HIPERFACE® interface e.g. LSH/LST H074-2-30-320/T1,G6M	KGH3-KSxxx	X7

Table 3.13 Variants of motors, encoder type and encoder cable



NOTE: Do not split the encoder cable, for example to route the signals via terminals in the control cabinet. The knurled screws on the D-Sub plug housing are tightly locked!

3.13.3 Ready made-up encoder cables

The specifications can only be assured when using the LTI system cables.

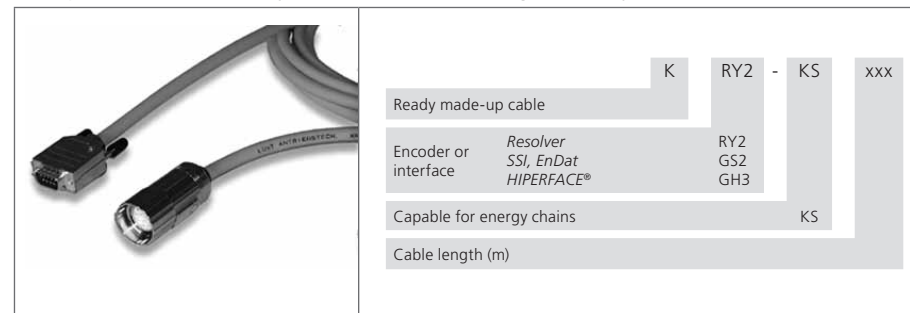

Encoder cable KRY2-KS-xxx

Oder code

Technical data

	KRY2-KSxxx	KGS2-KSxxx	KGH3-KSxxx
Motors with encoder system	Resolver	G3, G5, G12.x (single- / multiturn encoders with SSI-/EnDat interface)	G6, G6.x (single- / multiturn encoder with HIPERFACE® interface)
Assignment on control-ler side (Sub-D-plug)	1 = S2 2 = S4 3 = S1 4 = n.c. 5 = PTC+ 6 = R1 7 = R2 8 = S3 9 = PTC-	1 = A- 2 = A+ 3 = VCC (+5 V) 4 = DATA+ 5 = DATA- 6 = B- 8 = GND 11 = B+ 12 = VCC (Sense) 13 = GND (Sense) 14 = CLK+ 15 = CLK- 7, 9, 10 = n.c.	1 = REFCOS 2 = +COS 3 = U _s 7 – 12 V 4 = Data+ RS485 5 = Data- RS485 6 = REFSIN 7 = Jumper to PIN 12 8 = GND 11 = +SIN 12 = Jumper to PIN 7 9, 10, 13, 14, 15 = n.c.
Capable for energy chains	yes		
Minimum bending radius	90 mm	100 mm	90 mm

Table 3.14 Technical data encoder cable

	KRY2-KSxxx	KGS2-KSxxx	KGH3-KSxxx
Temperature range	-40 ... +85 °C	-35 ... +80 °C	-40 ... +85 °C
Cable diameter approx.	8.8 mm		
Material of oversheath	PUR		
Resistance	against oil, hydrolysis and microbial activity (VDE0472)		
Certifications	UL-Style 20233, 80 °C - 300 V, CSA-C22.2N.210-M90, 75 °C - 300 V FT1		

Table 3.14 Technical data encoder cable

3.13.4 Resolver connection

A resolver is connected to board slot X6 (9-pin D-Sub socket).

Fig.	X6/Pin	Function
	1	Sin+ / (S2) analog differential input track A
	2	REFSIN / (S4) analog differential input track A
	3	Cos+ / (S1) analog differential input track B
	4	Supply voltage 5..12 V, internally connected with X7/3
	5	⌀+ (PTC, KTY, Klixon) ¹⁾
	6	Ref+ analog excitation
	7	Ref- analog excitation (ground reference point to pin 6)
	8	REFCOS / (S3) analog differential input track B
	9	⌀- (PTC, KTY, Klixon) ¹⁾

Table 3.15 Pin assignment X6



¹⁾ ATTENTION! The motor's PTC (also KTY and Klixon) must be designed with reinforced insulation acc. to EN 61800-5-1 against motor winding.

3.13.5 Connection for high resolution encoders

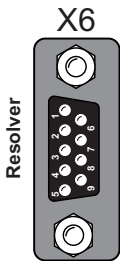
The interface X7 enables the evaluation of the following encoder types.

Fig.	Function
	SinCos encoder with index signal e.g. Heidenhain ERN1381, ROD486
	Heidenhain SinCos encoder with EnDat interface e.g. 13 bit singleturn encoder (ECN1313.EnDat01) and 25 bit multiturn encoder (EQN1325-EnDat01)
	Heidenhain encoder with digital EnDat interface Single- or multiturn encoder
	SinCos encoder SSI interface e.g. 13 bit singleturn and 25 bit multiturn encoder (ECN413-SSI, EQN425-SSI)
	Sick-Stegmann SinCos encoder with HIPERFACE® interface Single- and multiturn encoder, e.g. SRS50, SRM50

Table 3.16 Suitbale encoder types on X7



NOTES:

- The usage of encoders not included in the range supplied by LTI requires special approval by LTI DRIVES.
- The maximum signal input frequency is 500 kHz.
- Encoders with a voltage supply of 5 V ± 5 % must have a separate encoder cable connection. The encoder cable serves the detection of the actual supply voltage on the encoder, whereby a compensation of the voltage drop on the cable is achieved. Only the use of the encoder cable assures that the encoder is supplied with the correct voltage. The encoder line must always be connected.

Select the cable type specified by the motor or encoder manufacturer. Thereby please observe the following boundary conditions:

- Always used shielded cables. The shielding must be placed on both sides of the cable.
- Connect the differential track signals A, B, R or CLK, DATA to each other via twisted wires.
- Do not separate the encoder cable, for example to route the signals via terminals in the control cabinet.

Fig.	X7 Pin	SinCos and TTL	SinCos Absolute value encoder SSI/EnDat	Absolute value encoder EnDat (digital)	Absolute value encoder HIPERFACE®
	1	A-	A-	-	REFCOS
	2	A+	A+	-	+COS
	3	+5 V DC ±5%, IOU _T max = 250 mA (150 mA for Hardware versions 0..1), monitoring via sensor line			7 to 12 V (typ. 11 V) max. 100 mA
	4	-	Data +	Data +	Data +
	5	-	Data -	Data -	Data -
	6	B-	B-	-	REFSIN
	7	-	-	-	U _s - Switch
	8	GND	GND	GND	GND
	9	R-	-	-	-
	10	R+	-	-	-
	11	B+	B+	-	+SIN
	12	Sense +	Sense +	Sense +	U _s - Switch
	13	Sense -	Sense -	Sense -	-
	14	-	CLK+	CLK+	-
	15	-	CLK -	CLK -	-



The sum of the currents drawn at X7/3 and X6/4 must not exceed the value given!

After connecting pin 7 and pin 12 a voltage of 11.8 V will be applied to X7, pin 3!

Table 3.17 Pin assignment of plug connection X7



NOTE: The encoder supply on X7/3 is short-circuit proof in both 5 V and 11 V operation. The controller remains in operation such that on the evaluation of encoder signals a corresponding error message can be generated.

3.14 Motor connection

Step	Action	Comments
1.	Determine the cable cross-section, depending on maximum current and ambient temperature.	Cable cross-section acc. to local and country specific regulations and conditions.
2.	Connect the shielded motor cable to the terminals X12/ u, V, W and connect the motor to ground \oplus .	Mount screen at both ends to reduce interference emission. Fasten the shield connecting plate of the motor connection X12 with both screws.
3.	Wire the temperature sensor PTC (if available) to X5 with separately shielded cables and activate the temperature evaluation via DriveManager 5.	Mount screen at both ends to reduce interference emission.



ATTENTION!

- The temperature sensor connection can also be routed through the resolver line to X6/5 and 9. However, this requires a reinforced insulation acc. to EN 61800-5-1 between PTC and motor winding (e.g. LSH/LST-motor).
- For the connection X5 it must be assured that the temperature watchdog used is equipped with a basic insulation acc. to EN 61800-5-1 against the motor winding.



NOTE: In the event of a short-circuit or ground fault in the motor cable, the power stage is disabled and an error message is emitted.

3.14.1 Motor connection on LSH/LST-motors

 **NOTE:** Please use a ready made-up motor cable to connect servo motors of series LSH xxx and LST xxx.

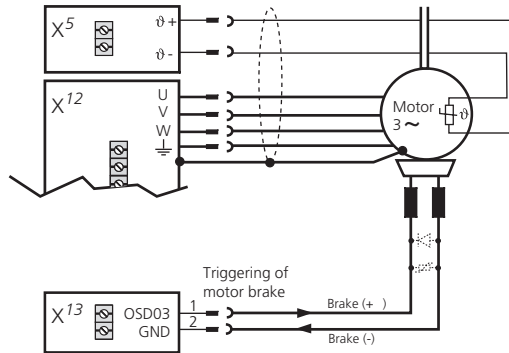

Fig. 3.16 Connection of motor for BG1 to BG4

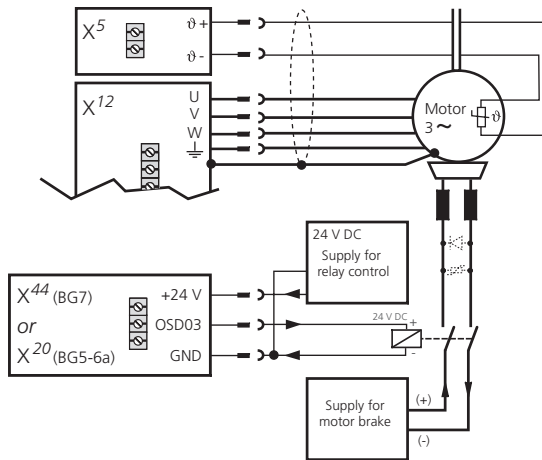



Fig. 3.17 Connection of motor for BG5 to BG7

3.14.2 Ready made-up motor cable



		KMx	-	KS		xxx	-	xxx
ready made-up motor cable	4 + 2 x 2 cores	3						
	4 cores	4						
Capable for energy chains				KS				
Cable length	in metres							
Motor cable	to I _o = 16 A							-
	to I _o = 24 A (only KM3)							24 A
	to I _o = 63 A (only KM3)							63 A

Motor cable KM3-KSxxx

Order code

Technical data motor cable

	KM2/3-KSxxx	KM2/3-KSxxx-24A	KM2/3-KSxxx-63A
for motors with pluggable power connection	to I _N = 16 A	to I _N = 24 A	to I _N = 63 A
Minimum bending radius for stationary routing	60 mm	75 mm	110 mm
Minimum bending radius for flexible applications	120 mm	150 mm	220 mm
Temperature range	-50 ... +90 °C		
Cable diameter approx.	12 mm	15 mm	22 mm
Cable cross-section	4G1.5 + 2 x 2 x 0.75 mm ²	4G2.5 + 2 x 2 x 1 mm ²	4G10 + 2 x 1.5 mm ² + 2 x 1 mm ²
Material of oversheath	PUR		
Resistance	against oil, hydrolysis and microbial activity (VDE0472), UL 20233, 80 °C - 300 V		
Assignment of strands	U = 1 V = 2 W = 3 Ground = ye/gn PTC = 5 PTC = 6 Brake + = 7 Brake - = 8		
Certification	UL-Style 20234, 80 °C - 1000 V CSA-C22.2 N.210-M90, 80 °C - 1000 V FT1		

Table 3.18 Technical data motor cable



NOTE: Strands 5 and 6 (PTC) are only required for motors with optical sensors (G12, G13, G6, G6M). On the LSH/LST xxx motors with resolver PTC-monitoring is connected via the resolver cable.

3.14.3 Switching in the motor cable



ATTENTION! Switching in the motor cable must generally take place in deenergized state and with deactivated power stage, as otherwise problems, such as burned off contactor contacts, will occur. In order to assure deenergized switching on you must make sure that the contacts of the motor contactor are closed before the drive controller power stage is released. In the moment the contactor switches off the contacts must remain closed, until the drive controller power stage has been switched off and the motor current has dropped to 0. This can be achieved by providing the control sequence of your machine with appropriate safety periods for the switching of the motor contactor.

However, despite these measures it cannot be ruled out, that the drive controller will malfunction when switching in the motor cable.

3.15 Braking resistor (RB)

In regenerative operation, e.g. when braking the drive, the motor feeds energy back to the drive controller. This increases the voltage in the DC link. If the voltage exceeds a switch-on threshold, the internal brake chopper transistor is activated and a braking resistor converts the regenerated power into heat.

Device	Mains voltage				
	1 x 230 V	3 x 230 V	3 x 400V	3 x 460V	3 x 480V
SO82.004	390 V DC	-	-	-	-
SO84.004 to SO84.032	-	390 V DC	650 V DC	745 V DC	765 V DC
SO84.045 to SO84.450	-	820 V DC	820 V DC	820 V DC	820 V DC

Table 3.19 Brake chopper switch-on thresholds (DC link voltage)

3.15.1 Protection in case of a brake chopper fault



ATTENTION! If the internal brake chopper transistor is permanently switched on, because it is alloyed through by overload ($= 0 \Omega$), there is a protective function to protect the device against overheating.

You activate this function via DriveManager 5 by assigning "BC_FAIL(56)" to any digital output (expert field "Inputs/outputs" -> "Digital outputs" -> OSD00 to OSD02) with "BC_FAIL(56)". In case of a fault the selected output will switch from 24 V to 0 V. This signal ensures that the drive controller is safely disconnected from the mains supply.

Detailed information on parameterization can be found in the ServoOne User Manual.

3.15.2 Design with integrated braking resistor BG1-4

The catalogue only specifies the peak braking power for the drive controller with integrated braking resistor (design SO8x.xxx.xxxx.1xxx, only available up to and including BG4). The permissible permanent braking power must be calculated. It depends on the effective loading of the controller in the corresponding application.



ATTENTION! No additional external braking resistor must be connected to the drive controller SO84.008 to SO84.032 with integrated braking resistor.

In general the drive controller is thermally designed in such a way, that no energy input by the internal braking resistor is permitted during continuous operation with rated AC current and under max. ambient temperature. Thus the controller design with integrated braking resistor only makes sense, if the effective drive controller load is $\leq 80\%$, or the braking resistor has been planned for one-time emergency stopping. In case of an emergency stop the heat capacity of the braking resistance can only be utilized for a single braking operation. The permissible energy W_{IBr} can be taken from the following table.

Device	Technology	Rated resistance R_{BR}	Peak braking power P_{PBr}	Pulse energy W_{IBr}	K1
SO82.004	PTC		1690 W ¹⁾	600 Ws	95 W
SO84.004 SO84.006			1690 W ²⁾		95 W
SO84.008 SO84.012	Wire resistance	90 Ω	4700 W ³⁾ 6170 W ⁴⁾ 6500 W ⁵⁾	6000 Ws	230 W
SO84.016 SO84.020					360 W
SO84.024 SO84.032					480 W

1) Data referred to 1 x 230 V mains voltage (BR switch-on threshold 390 V_{DC})
 2) Data referred to 3 x 230 V mains voltage (BR switch-on threshold 390 V_{DC})
 3) Data referred to 3 x 400 V mains voltage (BR switch-on threshold 650 V_{DC})
 4) Data referred to 3 x 460 V mains voltage (BR switch-on threshold 745 V_{DC})
 5) Data referred to 3 x 480 V mains voltage (BR switch-on threshold 765 V_{DC})

Table 3.20 Data of the integrated braking resistor (design SO8x.xxx.xxxx.1xxx)

If the drive is not permanently operated at its power limit, the reduced power dissipation of the drive can be used as braking power.



NOTE: Further calculation assumes that the drive controller is used at max. permissible ambient temperature. This means that any additional energy input from the internal braking resistor caused by low ambient temperature will be neglected.

To calculate the continuous braking power please proceed as follows:

- Calculation of the effective utilization of the drive controller during a cycle T:
- Determination of the permissible continuous braking power on basis of unused drive power:

$$I_{eff} = \sqrt{\frac{1}{T} \int_0^T i^2 dt}$$

$$P_{DBr} = \left(1 - \frac{I_{eff}}{I_N}\right) \times K1$$

Boundary conditions

- A single braking process must not exceed the maximum pulse energy of the braking resistor.
- The continuous braking power calculated for the device must be greater than the effective braking power of a device cycle.

$$W_{IBr} \geq P_{PBr} \times T_{Br}$$

$$P_{DBr} \geq \frac{1}{T} \times \int_0^T P_{PBr} dt_{Br}$$

This results in the minimum permissible cycle time T with calculated continuous braking power:

$$T = \frac{P_{PBr}}{P_{DBr}} \times \int_0^T dt_{Br}$$

The maximum total switch-on time of the braking resistor over a specified cycle time T with calculated continuous braking power results from:

$$T_{BrSum} = \frac{P_{DBr}}{P_{PBr}} \times T$$

3.15.3 Design with integrated braking resistor BG5-7

Drive controllers of sizes 5-7 with liquid cooling can be equipped with an integrated braking resistor as an option. You will find the related technical data in chapter A.2 from page 62.

3.15.4 Connection of an external braking resistor



DANGER CAUSED BY HIGH VOLTAGE! Danger to life! Terminal L+ (BG1 to BG4) or BR+ (BG5 to BG7) is fixed connected to DC link (>300 V DC). The connection is not fuse protected inside the device. Never wire or disconnect electrical connections while these are live! Always isolate the device from the mains supply before working on it. Even 30 minutes after switching off the mains supply dangerously high voltages of ≥ 50 V may still be present (capacitor charge). Therefore check for isolation from supply!



ATTENTION!

- Strictly follow the assembly instructions for the braking resistor.
- The temperature sensor (bimetal switch) on the braking resistor must be wired in such a way, that the power stage is deactivated and the connected servo controller is disconnected from the mains supply if the braking resistor overheats.
- The externally installed braking resistor must not be less than the minimum braking resistance permitted and the permitted continuous braking power must not be exceeded, technical data see section A.2 starting with page 62.
- The braking resistor must be connected with a shielded cable.

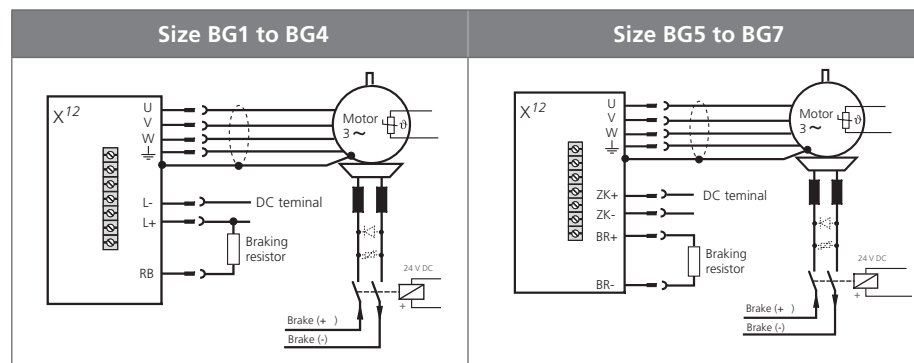



Fig. 3.18 Connection of braking resistor



ATTENTION! No additional external braking resistor must be connected to the drive controller with integrated braking resistor.

Available braking resistors (excerpt)

Ordering designation	Continuous braking power	Resistance ¹⁾	Peak braking power ²⁾	Degree of protection	Illustration
BR-200.01.540-UR	35 W	200 Ω	2800 W	IP54	 Example: BR-090.01.540-UR
BR-200.02.540-UR	150 W		2800 W	IP54	
BR-200.03.540-UR	300 W		2800 W	IP54	
BR-090.01.540-UR	35 W	90 Ω	6250 W	IP54	
BR-090.02.540-UR	150 W		6250 W	IP54	
BR-090.03.540-UR	300 W		6250 W	IP54	
BR-090.10.650-UR	1000 W	26 Ω	6250 W	IP65	
BR-026.01.540-UR	35 W		21600 W	IP54	
BR-026.02.540-UR	150 W		21600 W	IP54	
BR-026.03.540-UR	300 W	20 Ω	21600 W	IP54	
BR-026.10.650-UR	1000 W		21600 W	IP65	
BR-020.03.540-UR	300 W		27750 W	IP54	
BR-015.03.540-UR	300 W	15 Ω	37000 W	IP54	

1) Tolerance $\pm 10\%$

2) the maximum possible braking power in dependence on ON-time and cycle time

Table 3.21 Technical data - braking resistors



NOTE: Exact specifications, especially with respect to surface temperature, max. connection voltage and high voltage strength can be found in the ServoOne System Catalogue.

Please consult your projecting engineer for more detailed information on the design of braking resistors.

4 Commissioning

4.1 Notes for operation



ATTENTION!

- **Notes on safety**

During operation pay attention to the notes on safety in chapter 1.

- **During operation**

Strictly avoid that ...

- foreign objects or moisture enters into the device
- aggressive or conductive substances are in the vicinity
- ventilation openings are covered

- **Cooling**

- The device heats up during the operation and the temperature on the heat may reach 100 °C. Danger of skin injury when touching.
- Cooling air must be able to flow through the device without restriction.

4.2 Initial commissioning

Once the ServoOne has been installed as described in chapter 2. and wired with all required voltage supplies and external components as described in chapter 3., initial commissioning can be performed in the following sequence:

Step	Action	Comment
1.	Installation and start of PC software	see Installation Manual DriveManager 5
2.	Switching on control voltage	see section 4.2.1
3.	Connection between PC and drive controller	see section 4.2.2
4.	Parameter setting	see section 4.2.3
5.	Drive control with DriveManager 5	see section 4.2.4



NOTE: Details concerning STO (Safe Torque Off) have not been taken into account for initial commissioning. You will find all information on the "STO" function in the 24-language document "Description of the STO Safety Function" (Id.-No. 1100.10B.x).

4.2.1 Switching on control supply

- 2.** First only switch on the 24 V control supply for initializing and parameterizing. Do **not** yet switch on the AC mains supply.

Display reading after switching on the control supply

D1	D2	Action	Explanation
0		Switching on the external 24 V control supply	Initialization is running
5.1		Initialization completed	Not ready for starting

Table 4.1 Switch-on status of the ServoOne (after connection of the 24 V DC control supply)

- NOTE:** Details concerning the control supply can be found in section 3.7 "Connection of supply voltages" starting at page 26.

4.2.2 Connection between PC and drive controller

- 3.** The PC can be linked with the drive controller via uSB or Ethernet (TCP/IP). Connect PC and drive controller with the required connecting cable.

- NOTES:**
- **Initialization**
The communication link between PC and drive controller can only be set up after the drive controller has completed the initialization.
 - **USB driver and TCP/IP configuration**
If the PC does not recognize the connected drive controller you should check the driver or the settings for the corresponding interfaces (see installation manual DriveManager 5).

4.2.3 Parameter setting

- 4.** The Commissioning Wizard in DriveManager 5 helps to make settings to the drive system. Start the wizard.



NOTES:

- **Help system**
A detailed description of DriveManagers 5 as well as the commissioning wizard can be found in the DriveManager 5 help system.
- **Motor dataset**
When using LTI servo motors type LSH or LST the latest version of the required motor dataset can be downloaded from <http://drives.lt-i.com>, category "Downloads".

4.2.4 Drive control with DriveManager 5

- 5.** Switch on the AC mains supply. Subsequently enable the power stage and activate the controller. The drive should be tested without the coupled mechanics.



DANGER CAUSED BY ROTATING PARTS! Danger to life from uncontrolled rotation! Before starting motors with feather keys in the shaft end these must be reliably secured against being ejected, as far as this is not already prevented by drive elements such as belt pulleys, couplings or similar.



ATTENTION!

- **Avoid damage caused by motor test run!**
In this case it must be assured that the test will not cause any damage to the system! Pay particular attention to the limitations of the travel range. Please note that you yourself are responsible for safe operation. LTI DRIVES GmbH will not assume liability for any occurring damage.

• Destruction of motor!

- Certain motors are intended for operation on the drive controller. Direct connection to the mains supply can destroy the motor.
- The motor surfaces may become extremely hot. No temperature sensitive parts may touch or be mounted to these areas, appropriate measures to prevent contact must be applied wherever necessary.
- In order to avoid overheating of the motor, the temperature sensor installed in the winding must be connected to the terminals of the temperature monitoring system for the drive controller (X5 or X6).
- The motor brake (if installed) should be checked for fault-free functioning before commissioning of the motor. Standstill holding brakes are only designed for a limited number of emergency braking operations. se as working brake is strictly prohibited.

Display reading after switching on the AC mains supply

D1	D2	Action	Reaction	Explanation
5.2		Switching on the AC mains supply	Control ready, power stage ready, control deactivated	Device is ready for switching on

Table 4.1 Display D1/D2 after switching on the AC mains supply



NOTES:

• Inputs "ISDSH" and "ENPO"

For step 1 in table 4.2 at least the two inputs "ISDSH" and "ENPO" for terminal X4 must be interconnected.

• Manual operation dialog

Step 2 in table 4.2 best via the "Manual operation" dialog of DriveManager 5, details can be found in the help system.

• Configuration of inputs/outputs

If step 2 is to be executed via the inputs of terminal X4, the sources for "START CONTROL" and speed setpoint must be configured accordingly in the subject area "Inputs/Outputs" of DriveManager 5.

Switching on sequence to start the drive

1. Deactivate the safety function "STO" by setting the inputs ISDSH" and "ENPO"	
2. Activate "START CONTROL" at the earliest 2 ms after step 1 and specify the speed setpoint	
3. Monitor your system or plant and check the drive behaviour.	

t = motor dependent delay time

Table 4.2 Switching on sequence

Display reading after start of drive

D1	D2	Action	Reaction	Explanation
3		Enable "STO" and power stage "ENPO"	Ready for switching on	Power stage ready
		ATTENTION! Before the next step "Enable start" you must specify a plausible setpoint, because the pre-set setpoint is transferred to the drive directly after the motor control has started.		
5		"Start" enabled	Switched on	Motor energized, control active

Table 4.3 Display D1/D2 during activation of motor

Details for optimizing the drive on your application can be found in the DriveManager 5 Online help and in the ServoOne application manual.

4.3 Serial commissioning

An existing parameter dataset can be transferred to other ServoOne drive controllers by using DriveManager 5 or a MMC-card. Details can be found in the DriveManager 5 help system or in section 4.4.3.



NOTE: iPlc programs can only be loaded to a ServoOne drive controller by using the programming software CoDeSys.

4.4 Integrated control unit and MMC-card

The device internal control unit enables diagnosing the ServoOne. Moreover, using the MMC-card eases series commissioning without PC. The control unit consists of the following elements, which are all located on the front of the device:

- 2-digit 7-segment display (D1, D2)
- two buttons (T1, T2)
- MMC-Slot (X1)
LTi MMCplus cards of type SC-MMC128 can be used (128 MB memory and 3.3 V supply voltage, for further details see ServoOne system catalogue).

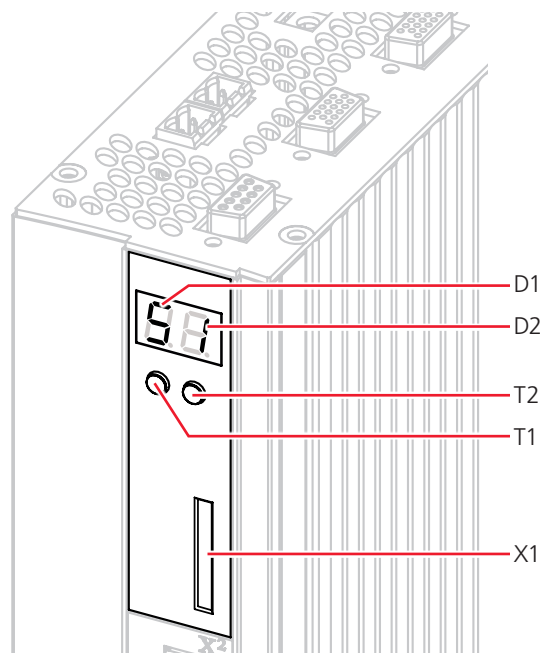

Fig. 4.1 Integrated control unit

The following functions or displays are available:

- Display of device status (see section 5.1.1 from page 51)
The device status is displayed after the control voltage has been switched on. If no input is made via the keyboard over a period of 60 seconds, the display returns to the device status display.
- Display of device error (see section 5.1.2 from page 51)
If a device error occurs the display will immediately change over an display the error code.
- Parameter setting (display "PA") (see section 4.4.3 from page 47)
To reset the device parameterization to factory settings as well as dataset handling via MMC-card
- Ethernet IP-address setting (display "IP") (see section 4.4.4 from page 48)
To set the Ethernet IP-address as well as the subnet maske
- Field bus settings (display "Fb") (see section 4.4.5 from page 49)
To set e.g. the field bus address
- Firmware update with MMC-card (see section 4.4.6 from page 50)

4.4.1 Function of buttons T1 and T2

These buttons are used to activate the different menus and to control the corresponding functions.

Button	Function	Comment
T1 (left)	<ul style="list-style-type: none"> Activation of menu (exit the device status display) Scrolling through the menus/sub-menus Setting of values - left segment display (D1) 	The button T1 can be held depressed for any time, because the display will only scroll through the menu options of the corresponding level. No settings will be changed.
T2 (right)	<ul style="list-style-type: none"> Selection of chosen menu Setting of values - right segment display (D2) 	The button T2 must not be held depressed for any length of time, because the display will change from one menu level to the next within the menu structure and then change the parameter that is reached at the end. You should therefore always release the button T2 after each change in display.
T1 and T2 together	<ul style="list-style-type: none"> Menu level up Accept selection Acknowledge 	When pressing T1 and T2 at the same time, the accepted value will be flashing for five seconds. During this time the Save procedure can still be aborted by pressing any button, without the set value being accepted. Otherwise the new value will be saved after 5 seconds.
General		<ul style="list-style-type: none"> The time the button needs to be held depressed until an action is executed, is approx. 1 second. If there is no action by the user over a period of 60 seconds, the display returns to the device status display.

Table 4.4 Function of buttons T1 and T2

4.4.2 Display

The following table defines various displays and status information about the display.

Display	Meaning
	Menu entries ("PA" in this case serves as an example, further possible entries see sections 4.4.4 and 4.4.5)
	[flashing decimal points] Selected function in action (e.g. writing/reading the MMC-card)
	[two dashes] Entry/function not available
	[OK] Action executed successfully, no errors
	[Error] <ul style="list-style-type: none"> Action via control unit not executed successfully, "Er" flashes in alternation with error number (see section 4.4.3) Display device error, "Er" flashes in alternation with error number and error location (see "ServoOne Application Manual")
	Numerical values ("10" in this case serves as an example) <ul style="list-style-type: none"> In the parameter menu (PA) dataset an error numbers are shown as decimal. All other values are displayed in hexadecimal mode. In these cases the displayed 10 would represent the decimal value 16.

Table 4.5 Meaning of display



NOTE: If no input is made via the keyboard over a period of 60 seconds, the display returns to the device status display.

4.4.3 Parameter menu (PA)

In the parameter menu the following functions are available:

- Reset the device setting to the factory setting
- Dataset handling with the MMC-card



NOTES:

- MMC operation is only possible if the power stage is **not** active.
- Accessing attempts to the MMC can take up to 2 minutes. Both decimal points are flashing during this time.

Menu level		Parameter	Value range	Meaning	Explanation
1	2				
PA	Pd	-	00..99	Parameter download *)	100 datasets (0..99) can be read from path: \PARA\TRANSFER\PDSxx.dmd (xx = 00.99) from the MMC.
	Pu	-	00..99	Parameter upload *)	100 datasets (0..99) can be saved to the MMC in the directory \PARA\TRANSFER\PDSxx.dmd. The directory is automatically created. Existing datasets can be overwritten.
	Pr	-	-	Parameter reset	To reset device settings to factory setting
	Pc	-	-	Parameter clear	To delete all datasets on the MMC-card.

*) MMC operation is only possible if the power stage is not active. Accessing attempts to the MMC can take up to 2 minutes.

Table 4.6 Parameter menu

Error numbers

A failed user action is indicated with an error message. The message consists of the alternating display of "Er" and the error number.



NOTE: The error messages within the scope of user input must not be mistaken as drive error messages. Detailed information concerning the error codes and error management can be found in the "ServoOne Application Manual".

Error number	Meaning
00	File System No Error
01	File System Any file system error
02	File System command rejected
03	File System function parameter invalid
04	File System create file error
05	File System open file error
06	MMC create directory failed
07	MMC mounting error
08	MMC unmounting error
09	MMC using not allowed with current technology option card
10	MMC error uninstall X12 card
11	MMC not inserted
12	MMC mounting, create node
13	MMC not supported by hardware (not NSP 257)
14	MMC device in control enabled
15	MMC load parameter dataset to device failed
16	MMC save parameter dataset failed
17	Parameter reset to factory settings failed
18	Parameter write access failed
19	Save parameter data set non volatile failed
20	Not all parameters written
21	Error while reset to factory settings

Table 4.7 Error numbers

4.4.4 Ethernet IP-address menu (IP)

An Ethernet TCP/IP interface serves the purpose of service and diagnostics interface. The IP-address is factory set to 192.168.39.5. It can be changed with the PC software DriveManager 5 or via the display.

Menu level		Parameter	Value range	Meaning	Explanation
1	2				
IP	lu	b0	00..FF	IP address update Byte 0	Setting of byte 0 of the IP-address in hexadecimal representation (e.g. "05" at 192.168.39.5)
		b1	00..FF	IP address update Byte 1	Setting of byte 1 of the IP-address in hexadecimal representation (e.g. "27" at 192.168.39.5)
		b2	00..FF	IP address update Byte 2	Setting of byte 2 of the IP-address in hexadecimal representation (e.g. "A8" at 192.168.39.5)
		b3	00..FF	IP address update Byte 3	Setting of byte 3 of the IP-address in hexadecimal representation (e.g. "C0" at 192.168.39.5)
	lr	-	-	IP reset to factory setting	To reset the IP-address to factory setting (192.168.39.5)
Su		b0	00..FF	Subnetmask update Byte 0	Setting of byte 0 of the subnet mask in hexadecimal representation (e. g. "00" at 255.255.255.0)
		b1	00..FF	Subnetmask update Byte 1	Setting of byte 1 of the subnet mask in hexadecimal representation (e. g. "FF" at 255.255.255.0)
		b2	00..FF	Subnetmask update Byte 2	Setting of byte 2 of the subnet mask in hexadecimal representation (e. g. "FF" at 255.255.255.0)
		b3	00..FF	Subnetmask update Byte 3	Setting of byte 3 of the subnet mask in hexadecimal representation (e. g. "FF" at 255.255.255.0)
	Sr	-	-	Subnetmask reset to factory setting	To reset the subnet mask to factory setting (255.255.255.0)

Table 4.8 IP-address menu

Exemplary configuration of the subnet mask

In this example the subnet mask is changed from 255.255.255.0 auf 122.255.255.0.

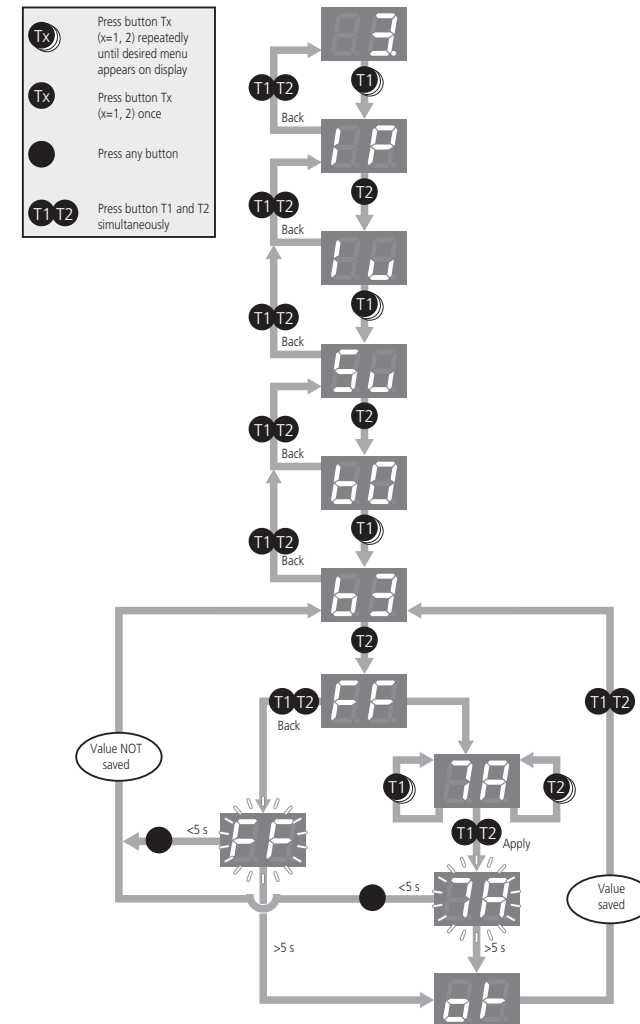

Fig. 4.2 Exemplary configuration of the subnet mask



NOTES:

- During the flashing phases the Save procedure can still be aborted by pressing any button, without the set value being accepted. Otherwise the new value will be saved after 5 seconds.
- Without a restart of the control electronics a changed IP-address will not be accepted.

4.4.5 Field bus address menu (Fb)

The functions available under this menu option depend on the expansion option of the device. Detailed information can be found in the corresponding model description.

Menu level 1	Menu level 2	Parameter	Value range	Meaning	Explanation
Fb	Ad	-	00..xx or --	Field bus address	Setting the field bus address (only with implemented field bus option), otherwise display "--" (the max. adjustable value depends on the option)
	Po	-	0..3 or --	Transmit power	Setting the light wave power (only with SERCOS II option), otherwise display "--"

Table 4.9 Field bus address menu

Exemplary configuration of the field bus address

In this example the field bus address is set from 1 to 23.

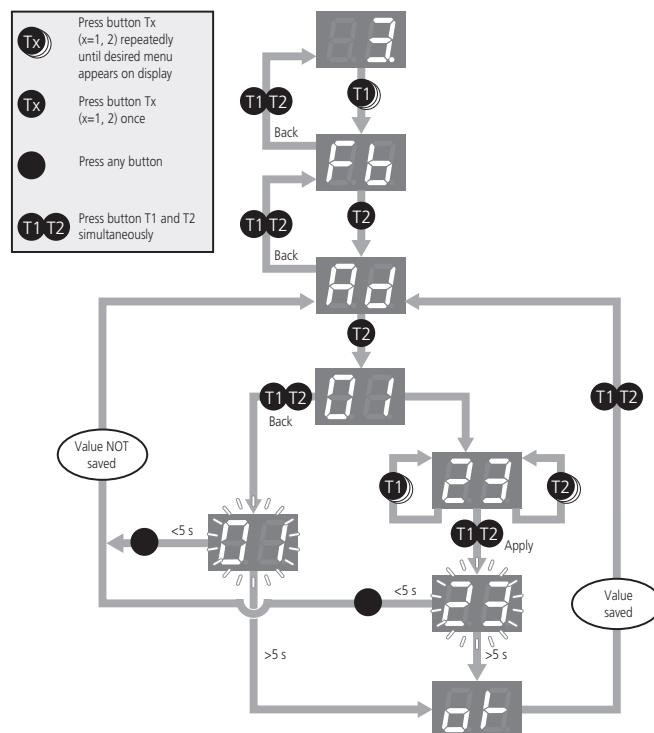

Fig. 4.3 Exemplary configuration of the field bus address

4.4.6 Firmware update with MMC-card

The MMC-card can be used to perform a Firmware update for the ServoOne. For this purpose the HEX-file of the Firmware to be updated with the file name "main.hex" must be copied into the directory "\Firmware\" in the root directory of the MMC-card.

The MMC-card prepared in this way must then be inserted into the ServoOne. Subsequently reset the 24 V DC control supply, while holding both buttons (T1 and T2) depressed at the same time. Once the display shows the code "c1" you may release both buttons.









The progress of the Firmware update appears in the display in form of a flashing dot after D2 and in succession with "c1" ... "c4". After a successful update the new Firmware will perform as usual. In case of an error the code "cE" will be displayed. In this case you must reset the 24 V DC control supply and repeat the download process.

5 Diagnosis

5.1 Status display on device

The 7-segment display on the device shows the device states.

5.1.1 Device states

Display	System status
	Device in reset state
	Automatic initializing during start-up of device
	Not ready to switch on (no DC link voltage) ¹⁾
	Starting lockout (DC link OK, power stage not ready) ¹⁾
	Switched on (drive powered)
	Switched on (drive energized) ²⁾
	Drive ready (drive energized and ready for setpoint specification) ²⁾
	Quick stop ²⁾
	Fault reaction active ²⁾

*) it is not a „safe indication“ as specified in EN EN 61800-5-2.
1) **S** flashes when the function STO (Safe Torque Off) is active, display goes out when the function is inactive.
2) This point flashes when the power stage is active.

Table 5.1 Device states

5.1.2 Error display

In each individual case the error codes will be displayed by the 7-segment display. Each error code consists of the repeating sequence of ►“Er” ►Error number ►Error location.



Display	Meaning
	Device error
↓ Display changes after approx. 1 s	
	Error number (decimal) Example: 05 = Overcurrent
↓ Display changes after approx 1 s	
	Error location (decimal) Example: 01 = Hardware monitoring
↑ After approx. 1 s the display jumps back to ER	

Table 5.2 Representation of the error code



NOTES:

- **Acknowledge error**

The errors can be acknowledged in accordance with their programmed reaction (ER) or only reset via a 24 V reset (X9/10) (ER.). Errors marked with a dot can only be reset, after the cause of the error has been eliminated.

- **Error code**

Detailed information concerning the error codes and error management can be found in the “ServoOne Application Manual”.

5.2 Status and error displays in DM5

A mouse click on the control button "Device status" in the header of the DM5 opens the "Device status" window.

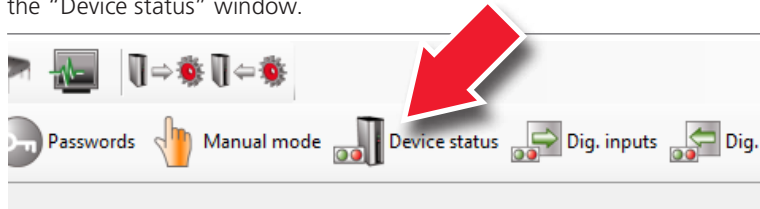

Fig. 5.1 Control button "Device status" in the header

With the control button "Error history..." you can call up information about the last 20 errors that have occurred.

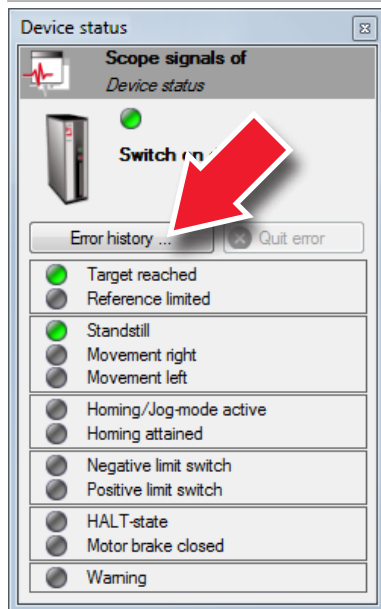

Fig. 5.2 "Device status" window

If an error occurs a "Pop-up" window with further information about the current error is automatically opened.

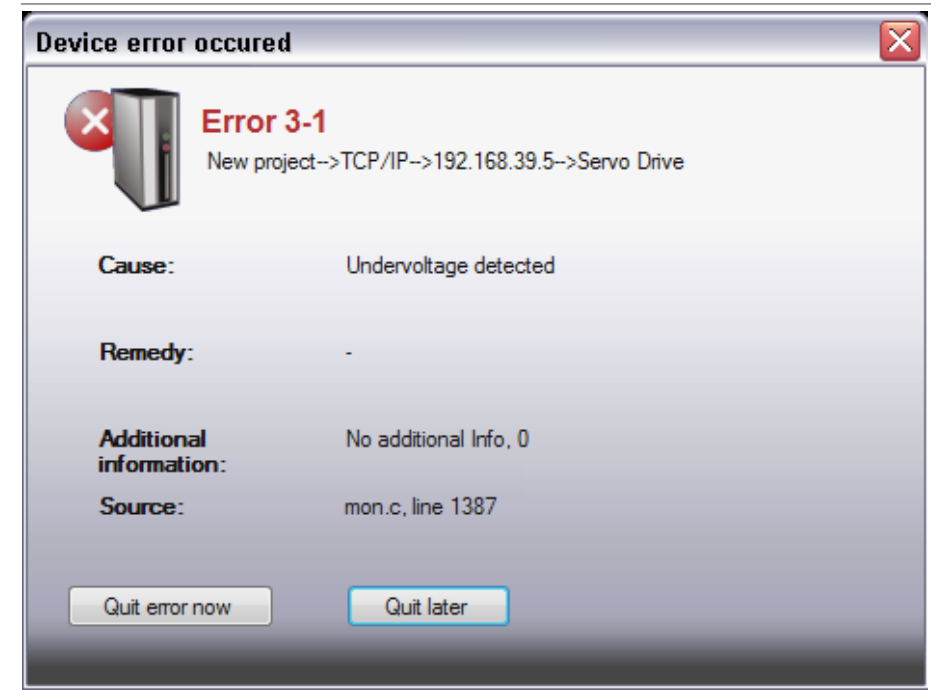

Fig. 5.3 Error message

Parameter 31 “Alarms & Warnings details” contains additional information on an actual error or a warning.

1. In the top area of the “Project” window choose “Number search” and enter the number “31” into the search field.
2. Then double-click on the lowest level “Alarm & warning details” in the project tree that has just opened.



NOTE: More detailed information on parameter 31 can be found in the “ServoOne Application Manual”.

	Actual error	1	2
Counter		2	3
Label	Fehler 3-1	Fehler 3-1	Fehler 45-1
Cause	Undervoltage detected	Undervoltage detected	New reference value violates lock or lin
Remedy	-	-	Quit error and change reference value
Operating hours [hh:mm:ss]	684:59:58	664:51:40	664:20:26
Info	No additional Info, 0	No additional Info, 0	No additional Info, 0
Source	../source/mon.c, line 1284	../source/mon.c, line 1284	../source/MPRO_CTRL.c, line 1705
DriveCom state	5 - Operation enabled	5 - Operation enabled	5 - Operation enabled
Operating hours (power stage) [hh:mm:ss]	122:43:52	122:40:4	122:34:43
Actual Current [A]		0.13068	0.0074295

Fig. 5.4 Parameter 31 “Alarms & Warnings (details)”

5.3 Helpline/Support & Service

If you have any questions concerning project planning or commissioning of your drive unit our Helpline is able to help you quickly and in an application oriented way. For this purpose you should have the following information at hand before you contact:

1. Type designation, 1. serial number and software version of the device (see rating plate software)
2. the DriveManager version used (Menu ► Help ► Information... ► Version)
3. displayed error code (as shown by the 7-segment display or the DriveManager)
4. Description of the error, its generation and boundary conditions
5. Save DriveManager device settings in a file
6. Name of company and contact, phone number and e-mail address

Our Helpline can be contacted via phone, e-mail oder internet:

Service time:	Monday to Friday from 8.00 a.m to 5.00 p.m (MEZ)
Telefon:	+49 6441 966-180
E-Mail:	helpline@lt-i.com
Internet:	http://drives.lt-i.com ► Support & Service ► Trouble Ticket

If you are looking for further assistance in service incidents, we - the specialists from the Service & Support-Center - will be glad to help you.

Service time:	Monday to Friday from 8.00 a.m to 5.00 p.m (MEZ)
Telefon:	+49 6441 966-888
E-Mail:	service@lt-i.com



NOTE: If you need any further advice, you will find all services we offer in our order catalogue "Support & Service". You can download the order catalogue from our website <http://drives.lt-i.com> under the category with the name.

6 Safe Torque Off (STO)



NOTE: You will find all information on the "STO" function in the 24-language document "Description of the STO Safety Function" (Id.-No. 1100.10B.x).

A Appendix

A.1 Permissible current load for drive controllers

The maximum permissible drive controller output current as well as the peak current are dependent on the mains voltage, the motor cable length, the power stage switching frequency, the design of cooling technology and the ambient temperature. The maximum permissible current carrying capacity of the drive controllers changes with any change in application related conditions.

A.1.1 Current carrying capacity BG1, air cooling, single-phase

Drive controller	Switching frequency of the power stage [kHz]	Ambient temperature [°C]	Rated current at 230 V _{AC} [A _{eff}]	Peak current [A _{eff}]			for time ¹⁾ [s]
				with linear increasing rotating field frequency 0 to 5 Hz	0 Hz	5 Hz	
SO82.004 (BG1)	4	45	4.0	8.0	8.0	8.0	10
	8	40	4.0	8.0	8.0	8.0	
	12		3.7	7.4	7.4	7.4	
	16		2.7	5.4	5.4	5.4	

Data apply for a motor cable length ≤10 m
 1) Shut-down according to I²t-characteristic

Table A.1 Rated and peak current BG1 (air cooling, single-phase)

A.1.2 Current carrying capacity BG1-BG4, air cooling, triple-phase

Drive controller	Switching frequency of the power stage [kHz]	Ambient temperature [°C]	Rated current			Peak current [A _{eff}]			for time ¹⁾ [s]
			at 400 V _{AC} [A _{eff}]	at 460 V _{AC} [A _{eff}]	at 480 V _{AC} [A _{eff}]	with linear increasing rotating field frequency 0 to 5 Hz	0 Hz	5 Hz	
SO84.004 (BG1)	4	45	4.0	4.0	4.0	8.0	8.0	8.0	10
	8	40	4.0	4.0	4.0	8.0	8.0	8.0	
	12		3.7	2.9	2.7	7.4	7.4	7.4	
	16		2.7	1.6	1.3	5.4	5.4	5.4	
SO84.006 (BG1)	4	45	6.0	6.0	6.0	12.0	12.0	12.0	10
	8	40	6.0	6.0	6.0	12.0	12.0	12.0	
	12		5.5	4.4	4.0	11.0	11.0	11.0	
	16		4.0	2.4	1.9	8.0	8.0	8.0	
SO84.008 (BG2)	4	45	8.0	8.0	8.0	16.0	16.0	16.0	10
	8	40	8.0	7.2	6.9	16.0	16.0	16.0	
	12		6.7	5.3	4.9	13.4	13.4	13.4	
	16		5.0	3.7	3.3	10.0	10.0	10.0	
SO84.012 (BG2)	4	45	12.0	12.0	12.0	24.0	24.0	24.0	10
	8	40	12.0	10.8	10.4	24.0	24.0	24.0	
	12		10.0	8.0	7.4	20.0	20.0	20.0	
	16		7.6	5.6	5.0	15.2	15.2	15.2	

Data apply for a motor cable length ≤10 m.
 1) Shut-down according to I²t-characteristic

Table A.2 Rated and peak current BG1 to BG4 (air cooling, triple-phase)

Drive controller	Switching frequency of the power stage [kHz]	Ambient temperature [°C]	Rated current			Peak current [A _{eff}]			for time ¹⁾ [s]
			at 400 V _{AC}	at 460 V _{AC}	at 480 V _{AC}	with linear increasing rotating field frequency 0 to 5 Hz		for intermittent operation	
			[A _{eff}]	[A _{eff}]	[A _{eff}]	0 Hz	5 Hz	>5 Hz	
SO84.016 (BG3)	4	45	16.0	16.0	16.0	32.0	32.0	32.0	10
	8	40	16.0	13.9	13.3	32.0	32.0	32.0	
	12		11.0	8.8	8.0	22.0	22.0	22.0	
	16		8.0	5.9	5.2	16.0	16.0	16.0	
SO84.020 (BG3)	4	45	20.0	20.0	20.0	40.0	40.0	40.0	10
	8	40	20.0	17.4	16.6	40.0	40.0	40.0	
	12		13.8	11.0	10.0	27.6	27.6	27.6	
	16		10.0	7.4	6.5	20.0	20.0	20.0	
SO84.024 (BG4)	4	45	24.0	24.0	24.0	48.0	48.0	48.0	10
	8	40	24.0	21.0	20.0	48.0	48.0	48.0	
	12		15.8	12.4	11.3	31.6	31.6	31.6	
	16		11.3	9.2	8.4	22.6	22.6	22.6	
SO84.032 (BG4)	4	45	32.0	32.0	32.0	64.0	64.0	64.0	10
	8	40	32.0	28.0	26.7	64.0	64.0	64.0	
	12		21.0	16.5	15.0	42.0	42.0	42.0	
	16		15.0	12.2	11.2	30.0	30.0	30.0	

Data apply for a motor cable length ≤10 m.

1) Shut-down according to I²t-characteristic

Table A.2 Rated and peak current BG1 to BG4 (air cooling, triple-phase)

A.1.3 Current carrying capacity BG5-BG6a, air cooling

Drive controller	Switching frequency of the power stage [kHz]	Ambient temperature [°C]	Rated current			Peak current [A _{eff}]			for time ¹⁾ [s]
			at 400 V _{AC}	at 460 V _{AC}	at 480 V _{AC}	with linear increasing rotating field frequency 0 to 5 Hz		for intermittent operation	
			[A _{eff}]	[A _{eff}]	[A _{eff}]	0 Hz	5 Hz	>5 Hz	
SO84.045 (BG5)	4	45	45	42	41	90	90	90	3/10 ³⁾
	8	40	45	42	41	90	90	90	
	16		42	39	38	84	84	84	
SO84.060 (BG5)	4	45	60	56	54	120	120	120	3/10 ³⁾
	8	40	60	56	54	120	120	120	
	16		42	39	38	84	84	84	
SO84.072 (BG5)	4	45	72	67	65	144	144	144	3/10 ³⁾
	8	40	72	67	65	144	144	144	
	16		42	39	38	84	84	84	
SO84.090 (BG6)	4	45	90	83	81	170	180	180	30
	8	40	90	83	81	134	180	180	
	16		72	67	65	86	115	115	

Data apply for a motor cable length ≤10 m.

1) Shut-down according to I²t-characteristic2) Supply with 400 V_{AC} at max. 70% preload

3) 10 s at heat sink temperature <45 °C

Table A.3 Rated and peak current BG5 to BG6a (air cooling)

Drive controller	Switching frequency of the power stage [kHz]	Ambient temperature [°C]	Rated current			Peak current [A _{eff}]			for time ¹⁾ [s]
			at 400 V _{AC}	at 460 V _{AC}	at 480 V _{AC}	with linear increasing rotating field frequency 0 to 5 Hz		for intermittent operation	
			[A _{eff}]	[A _{eff}]	[A _{eff}]	0 Hz	5 Hz	>5 Hz	
SO84.110 (BG6)	4	45	110	102	99	170	220	220	30
	8	40	110	102	99	134	165	165	
	12		90	83	81	107	144	144	
	16		72	67	65	86	115	115	
SO84.143 (BG6a)	4	45	143	132	129	190	286	286	30
	8	40	143	132	129	151	215	215	
	12		115	106	104	121	172	172	
	16		92	85	83	97	138	138	
SO84.170 (BG6a)	4	45	170	157	153	190	315	315	10
	8	40	170	157	153	151	220	220	10
	12	-	-	-	-	-	-	-	-
	16	-	-	-	-	-	-	-	-

Data apply for a motor cable length ≤10 m.

1) Shut-down according to I²t-characteristic

2) Supply with 400 V_{AC} at max. 70% preload

3) 10 s at heat sink temperature <45 °C

Table A.3 Rated and peak current BG5 to BG6a (air cooling)

A.1.4 Current carrying capacity BG3-BG4, liquid cooling



NOTE: The shutdown temperature for liquid-cooled devices is (internally at the heat sink) 65 °C. The drive controller is shut down and operation can only be resumed after a short cooling phase.

Drive controller	Switching frequency of the power stage [kHz]	Ambient temperature [°C]	Rated current			Peak current [I_{eff}]			for time ¹⁾ [s]
			at 400 V _{AC}	at 460 V _{AC}	at 480 V _{AC}	with linear increasing rotating field frequency 0 to 5 Hz		for intermittent operation	
			[A _{eff}]	[A _{eff}]	[A _{eff}]	0 Hz	5 Hz	>5 Hz	
SO84.016 (BG3)	4	40	16.0	16.0	16.0	32.0	32.0	32.0	10
	8		16.0	13.9	13.3	32.0	32.0	32.0	
	12		11.0	8.8	8.0	22.0	22.0	22.0	
	16		8.0	5.9	5.2	16.0	16.0	16.0	
SO84.020 (BG3)	4	40	20.0	20.0	20.0	40.0	40.0	40.0	10
	8		20.0	17.4	16.6	40.0	40.0	40.0	
	12		13.8	11.0	10.0	27.6	27.6	27.6	
	16		10.0	7.4	6.5	20.0	20.0	20.0	
SO84.024 (BG4)	4	40	24.0	24.0	24.0	48.0	48.0	48.0	10
	8		24.0	21.0	20.0	48.0	48.0	48.0	
	12		15.8	12.4	11.3	31.6	31.6	31.6	
	16		11.3	9.2	8.4	22.6	22.6	22.6	
SO84.032 (BG4)	4	40	32.0	32.0	32.0	64.0	64.0	64.0	10
	8		32.0	28.0	26.7	64.0	64.0	64.0	
	12		21.0	16.5	15.0	42.0	42.0	42.0	
	16		15.0	12.2	11.2	30.0	30.0	30.0	

Data apply for a motor cable length ≤10 m.

1) Shut-down according to I²t-characteristic

2) Supply with 400 V_{AC} at max. 70% preload

Table A.4 Rated and peak current BG3 and BG4 (liquid cooling)

A.1.5 Current carrying capacity BG5-BG6a, liquid cooling



NOTE: The shutdown temperature for liquid-cooled devices is (internally at the heat sink) 65 °C. The drive controller is shut down and operation can only be resumed after a short cooling phase.

Drive controller	Switching frequency of the power stage [kHz]	Ambient temperature [°C]	Rated current			Peak current [I_{eff}]			for time ¹⁾ [s]
			at 400 V _{AC}	at 460 V _{AC}	at 480 V _{AC}	with linear increasing rotating field frequency 0 to 5 Hz		for intermittent operation	
			[A _{eff}]	[A _{eff}]	[A _{eff}]	0 Hz	5 Hz	>5 Hz	
SO84.045 (BG5)	4	45	53	49	48	90	90	90	30
	8		53	49	48	90	90	90	
	12		53	49	48	90	90	90	
	16		49	45	44	84	84	84	
SO84.060 (BG5)	4	45	70	65	63	120	120	120	30
	8		70	65	63	120	120	120	
	12		68	63	61	116	116	116	
	16		49	45	44	84	84	84	
SO84.072 (BG5)	4	45	84	78	76	144	144	144	30
	8		84	78	76	144	144	144	
	12		68	63	61	116	116	116	
	16		49	45	44	84	84	84	

Data apply for a motor cable length ≤10 m

1) Shut-down according to I²t-characteristic

2) Supply with 400 V_{AC} at max. 70% preload

Table A.5 Rated and peak current BG5 to BG6a (liquid cooling)

Drive controller	Switching frequency of the power stage [kHz]	Ambient temperature [°C]	Rated current			Peak current [A _{eff}]			for time ¹⁾ [s]
			at 400 V _{AC}	at 460 V _{AC}	at 480 V _{AC}	with linear increasing rotating field frequency 0 to 5 Hz		for intermittent operation	
			[A _{eff}]	[A _{eff}]	[A _{eff}]	0 Hz	5 Hz	>5 Hz	
SO84.090 (BG6)	4	45	110	102	99	205	220	220	30
	8		110	102	99	165	187	187	
	12		110	102	99	132	165	165	
	16		90	83	81	106	135	135	
SO84.110 (BG6)	4	45	143	132	129	230	286	286	30
	8		143	132	129	190	215	215	
	12		114	105	103	152	172	172	
	16		91	84	82	122	138	138	
SO84.143 (BG6a)	4	45	170	157	153	230	340	340	10
	8		170	157	153	190	255	255	
	12		136	126	122	152	204	204	
	16		109	101	98	122	163	163	
SO84.170 (BG6a)	4	45	210	194	189	230	340	340	10
	8	45	210	194	189	190	255	255	10
	12	-	-	-	-	-	-	-	-
	16	-	-	-	-	-	-	-	-

Data apply for a motor cable length ≤10 m
 1) Shut-down according to I²t-characteristic
 2) Supply with 400 V_{AC} at max. 70% preload

Table A.5 Rated and peak current BG5 to BG6a (liquid cooling)

A.1.6 Current carrying capacity BG7, liquid cooling



NOTE: The shutdown temperature for liquid-cooled devices is (internally at the heat sink) 65 °C. The drive controller is shut down and operation can only be resumed after a short cooling phase.

Drive controller	Switching frequency of the power stage [kHz]	Ambient temperature [°C]	Rated current			Peak current [A _{eff}]			for time ¹⁾ [s]
			at 400 V _{AC}	at 460 V _{AC}	at 480 V _{AC}	with linear increasing rotating field frequency 0 to 5 Hz		for intermittent operation	
			[A _{eff}]	[A _{eff}]	[A _{eff}]	0 Hz	5 Hz	>5 Hz	
SO84.250 (BG7)	2	40	250	231	225	425		30	
	4					375			
SO84.325 (BG7)	2	40	325	300	292	552		30	
	4					485			
SO84.450 (BG7)	2	40	450	416	405	765		30	
	4					675			

Data apply for a motor cable length ≤10 m
 1) Shut-down according to I²t-characteristic
 2) Supply with 400 V_{AC} at max. 70% preload

Table A.6 Rated and peak current BG7 (liquid cooling)

A.2 Technical data ServoOne

A.2.1 SO82.004 to SO84.016, air cooling

Designation	SO82.004	SO84.004	SO84.006	SO84.008	SO84.012	SO84.016
Technical data						
Output motor side ¹⁾						
Voltage	3-phase U _{mains}					
Rated current effective (I _N)	4 A	4 A	6 A	8 A	12 A	16 A
Peak current	see Table A.1	see Table A.2				
Rotating field frequency	0 ... 400 Hz					
Output stage switching frequency	4, 8, 12, 16 kHz					
Input mains supply side						
Mains voltage	1 x 230 V ±10%	(3 x 230 V / 3 x 400 V / 3 x 460 V / 3 x 480 V) ±10%				
Device connected load ¹⁾ (with mains choke)	1.6 kVA	2.8 kVA	4.2 kVA	5.9 kVA	8.8 kVA	11.1 kVA
Current ¹⁾ (with mains choke)	9.5 A ²⁾	4.2 A	6.4 A	8.7 A	13.1 A	17.3 A
Asymmetry of the mains voltage	-	±3% max.				
Frequency	50/60 Hz ±10%					
Power loss at I _N ¹⁾	85 W	96 W	122 W	175 W	240 W	330 W
¹⁾ Values related to a mains voltage of 3 x 400 V _{eff} (at SO82.004: 1 x 230 V _{eff}) and a switching frequency of 8 kHz ²⁾ without mains choke ³⁾ Connection of an ext. braking resistor is not permitted for devices with int. braking resistor (version SO8x.xxx.xxxx.1xxx)!						

Table A.7 Technical data SO82.004 bis SO84.016, air cooling

Designation	SO82.004	SO84.004	SO84.006	SO84.008	SO84.012	SO84.016
Technical data						
DC link						
Capacity	1740 µF	400 µF		725 µF		1230 µF
Brake chopper switch-on threshold ¹⁾	390 V DC	650 V DC				
Minimum ohmic resistance of an externally installed braking resistor ³⁾		72 Ω		39 Ω		20 Ω
Brake chopper continuous power with external braking resistor ¹⁾	2.1 kW	5.9 kW		11 kW		21 kW
Peak brake chopper chopper with external braking resistor ¹⁾	2.1 kW	5.9 kW		11 kW		21 kW
Optional: internal braking resistor		PTC				90 Ω
Brake chopper continuous power with internal braking resistor	see section 3.15.2					
Peak brake chopper chopper with internal braking resistor	see section 3.15.2					
¹⁾ Values related to a mains voltage of 3 x 400 V _{eff} (at SO82.004: 1 x 230 V _{eff}) and a switching frequency of 8 kHz ²⁾ without mains choke ³⁾ Connection of an ext. braking resistor is not permitted for devices with int. braking resistor (version SO8x.xxx.xxxx.1xxx)!						

Table A.7 Technical data SO82.004 bis SO84.016, air cooling



NOTE: For further information on brake chopper switch-on threshold please refer to chapter 3.15.

A.2.2 SO84.020 to SO84.072, air cooling

Designation	SO84.020	SO84.024	SO84.032	SO84.045	SO84.060	SO84.072
Technical data						
Output motor side ¹⁾						
Voltage	3-phase U _{Netz}					
Rated current effective (I _N)	20 A	24 A	32 A	45 A	60 A	72 A
Peak current	see Table A.2		see Table A.3			
Rotating field frequency	0 ... 400 Hz					
Output stage switching frequency	4, 8, 12, 16 kHz					
Input mains supply side						
Mains voltage	(3 x 230 V / 3 x 400 V / 3 x 460 V / 3 x 480 V) ±10%					
Device connected load ¹⁾ (with mains choke)	13.9 kVA	16.6 kVA	22.2 kVA	31 kVA	42 kVA	50 kVA
Current ¹⁾ (with mains choke)	21.6 A	26.2 A	34.9 A	45 A	60 A	72 A
Asymmetry of the mains voltage	±3% max.					
Frequency	50/60 Hz ±10%					
<small>1) Values related to a mains voltage of 3 x 400 V_{eff} (at SO82.004: 1 x 230 V_{eff}) and a switching frequency of 8 kHz</small>						
<small>3) Connection of an ext. braking resistor is not permitted for devices with int. braking resistor (version SO8x.xxx.xxx.1xxx)!</small>						

Table A.8 Technical data SO84.020 to SO84.072, air cooling

Designation	SO84.020	SO84.024	SO84.032	SO84.045	SO84.060	SO84.072
Technical data						
Power loss at I _N ¹⁾	400 W	475 W	515 W	610 W	830 W	1010 W
DC link						
Capacity	1230 µF	2000 µF	430 µF	900 µF		
Brake chopper switch-on threshold ¹⁾	650 V DC ¹⁾			820 V DC		
Minimum ohmic resistance of an externally installed braking resistor ³⁾	20 Ω ³⁾	12 Ω ³⁾	18 Ω		13 Ω	
Brake chopper continuous power with external braking resistor ¹⁾	21 kW ¹⁾	35 kW ¹⁾	37 kW		52 kW	
Peak brake chopper chopper with external braking resistor ¹⁾	21 kW ¹⁾	35 kW ¹⁾	37 kW		52 kW	
Optional: internal braking resistor	90 Ω			-		
Brake chopper continuous power mit internem Bremswiderstand	see section 3.15.2			-		
Peak brake chopper chopper with internal braking resistor	see section 3.15.2			-		
<small>1) Values related to a mains voltage of 3 x 400 V_{eff} (at SO82.004: 1 x 230 V_{eff}) and a switching frequency of 8 kHz</small>						
<small>3) Connection of an ext. braking resistor is not permitted for devices with int. braking resistor (version SO8x.xxx.xxx.1xxx)!</small>						

Table A.8 Technical data SO84.020 to SO84.072, air cooling



NOTE: For further information on brake chopper switch-on threshold please refer to chapter 3.15.

A.2.3 SO84.090 to SO84.170, air cooling

Designation	SO84.090	SO84.110	SO84.143	SO84.170
Technical data				
Output motor side ¹⁾				
Voltage	3-phase U_{mains}			
Rated current effective (I_N)	90 A	110 A	143 A	170 A
Peak current	see Table A.3			
Rotating field frequency	0 ... 400 Hz			
Output stage switching frequency	4, 8, 12, 16 kHz			
Input mains supply side				
Mains voltage	(3 x 230 V / 3 x 400 V / 3 x 460 V / 3 x 480 V) $\pm 10\%$			
Device connected load ¹⁾ (with mains choke)	62 kVA	76 kVA	99 kVA	118 kVA
Current ¹⁾ (with mains choke)	90 A	110 A	143 A	170 A
Asymmetry of the mains voltage	$\pm 3\%$ max.			
Frequency	50/60 Hz $\pm 10\%$			
Power loss at I_N ¹⁾	1300 W	1600 W	2100 W	2500 W

¹⁾ Values related to a mains voltage of 3 x 400 V_{eff} and a switching frequency of 8 kHz

Table A.9 Technical data SO84.090 to SO84.170, air cooling

Designation	SO84.090	SO84.110	SO84.143	SO84.170
Technical data				
DC link				
Capacity	1060 μF	2120 μF	3180 μF	4240 μF
Brake chopper switch-on threshold ¹⁾	820 V DC			
Minimum ohmic resistance of an externally installed braking resistor ³⁾	12 Ω	10 Ω	8.5 Ω	6.5 Ω
Brake chopper continuous power with external braking resistor ¹⁾	56 kW	65 kW	65 kW	65 kW
Peak brake chopper with external braking resistor ¹⁾	56 kW	67 kW	79 kW	103 kW
Optional: internal braking resistor	-	-	-	-
Brake chopper continuous power with internal braking resistor	-	-	-	-
Peak brake chopper with internal braking resistor	-	-	-	-

¹⁾ Values related to a mains voltage of 3 x 400 V_{eff} and a switching frequency of 8 kHz

Table A.9 Technical data SO84.090 to SO84.170, air cooling



NOTE: For further information on brake choppers please refer also to chapter 3.15.

A.2.4 SO84.016 to SO84.060, liquid cooling

Designation	SO84.016	SO84.020	SO84.024	SO84.032	SO84.045	SO84.060
Technical data						
Output motor side ¹⁾						
Voltage	3-phase U _{Net}					
Rated current effective (I _N)	16 A	20 A	24 A	32 A	53 A	70 A
Peak current	see Table A.4			see Table A.5		
Rotating field frequency	0 ... 400 Hz					
Output stage switching frequency	4, 8, 12, 16 kHz					
Input mains supply side						
Mains voltage	(3 x 230 V / 3 x 400 V / 3 x 460 V / 3 x 480 V) ±10%					
Device connected load ¹⁾ (with mains choke)	11.1 kVA	13.9 kVA	16.6 kVA	22.2 kVA	37 kVA	50 kVA
Current ¹⁾ (with mains choke)	17.3 A	21.6 A	26.2 A	34.9 A	53 A	70 A
Asymmetry of the mains voltage	±3% max.					
Frequency	50/60 Hz ±10%					
Power loss at I _N ¹⁾	330 W	400 W	475 W	515 W	690 W	930 W
¹⁾ Values related to a mains voltage of 3 x 400 V _{eff} and a switching frequency of 8 kHz ⁴⁾ Connection of an ext. braking resistor is not permitted for devices with int. braking resistor (version SO8x.xxx.xxxx.1xxx)! ⁵⁾ Cooling power sufficient even with optional internal braking resistor						

Table A.10 Technical data SO84.016 to SO84.060, liquid cooling

Designation	SO84.016	SO84.020	SO84.024	SO84.032	SO84.045	SO84.060
Technical data						
DC link						
Capacity	1230 µF		2000 µF		430 µF	900 µF
Brake chopper switch-on threshold	650 V DC ¹⁾			820 V DC		
Minimum ohmic resistance of an externally installed braking resistor	20 Ω		12 Ω		10 Ω ⁴⁾	
Brake chopper continuous power with external braking resistor	21 kW		35 kW		67 kW	
Peak brake chopper chopper with external braking resistor	21 kW		35 kW		67 kW	
Optional: internal braking resistor			-		20 Ω	10 Ω
Brake chopper continuous power with internal braking resistor			-		675 W	1350 W
Peak brake chopper chopper with internal braking resistor			-		34 kW	67 kW
Cooler data						
Coolant pressure (nom. value / max. value)	1 / 2 bar					
Coolant flow ⁵⁾ (nom. value / max. value)	3 / 4 l per min			8 / 11 l per min		
Feed coolant temperature	The coolant temperature can be between 5 °C and 40 °C. However, the coolant temperature should not be more than 10 °K below the ambient temperature, to avoid moisture condensation on the heat sink.					
¹⁾ Values related to a mains voltage of 3 x 400 V _{eff} and a switching frequency of 8 kHz ⁴⁾ Connection of an ext. braking resistor is not permitted for devices with int. braking resistor (version SO8x.xxx.xxxx.1xxx)! ⁵⁾ Cooling power sufficient even with optional internal braking resistor						

Table A.10 Technical data SO84.016 to SO84.060, liquid cooling

A.2.5 SO84.072 to SO84.210, liquid cooling

Designation	SO84.072	SO84.090	SO84.110	SO84.143	SO84.170
Technical data					
Output motor side ¹⁾					
Voltage	3-phase U_{Netz}				
Rated current effective (I_N)	84 A	110 A	143 A	170 A	210 A
Peak current	see Table A.5				
Rotating field frequency	0 ... 400 Hz				
Output stage switching frequency	4, 8, 12, 16 kHz				
Input mains supply side					
Mains voltage	(3 x 230 V / 3 x 400 V / 3 x 460 V / 3 x 480 V) $\pm 10\%$				
Device connected load ¹⁾ (with mains choke)	58 kVA	76 kVA	99 kVA	118 kVA	128 kVA
Current ¹⁾ (with mains choke)	84 A	110 A	143 A	170 A	185 A
Asymmetry of the mains voltage	$\pm 3\%$ max.				
Frequency	50/60 Hz $\pm 10\%$				
Power loss at I_N ¹⁾	1130 W	1500 W	1940 W	2380 W	2650 W
¹⁾ Values related to a mains voltage of 3 x 400 V _{eff} and a switching frequency of 8 kHz ⁴⁾ Connection of an ext. braking resistor is not permitted for devices with int. braking resistor (version SO8x.xxx.xxxx.7xxx)! ⁵⁾ Cooling power sufficient even with optional internal braking resistor					

Table A.11 Technical data SO84.072 to SO84.210, liquid cooling

Designation	SO84.072	SO84.090	SO84.110	SO84.143	SO84.170
Technical data					
DC link					
Capacity	900 μF	2120 μF	4240 μF		
Brake chopper switch-on threshold	820 V DC				
Minimum ohmic resistance of an externally installed braking resistor	10 Ω	12 Ω	10 Ω	8.5 Ω	6.5 Ω
Brake chopper continuous power with external braking resistor	67 kW	56 kW	67 kW	79 kW	103 kW
Peak brake chopper chopper with external braking resistor	67 kW	56 kW	67 kW	79 kW	103 kW
Optional: internal braking resistor	10 Ω	7.5 Ω	5 Ω		
Brake chopper continuous power with internal braking resistor	1350 W	2650 W	4000 W		
Peak brake chopper chopper with internal braking resistor	67 kW	90 kW	135 kW		
Cooler data					
Coolant pressure (nom. value / max. value)	1 / 2 bar				
Coolant flow ⁵⁾ (nom. value / max. value)	8 / 11 l per min	11 / 13 l per min			
Feed coolant temperature	The coolant temperature can be between 5 °C and 40 °C. However, the coolant temperature should not be more than 10 °K below the ambient temperature, to avoid moisture condensation on the heat sink.				
¹⁾ Values related to a mains voltage of 3 x 400 V _{eff} and a switching frequency of 8 kHz ⁴⁾ Connection of an ext. braking resistor is not permitted for devices with int. braking resistor (version SO8x.xxx.xxxx.7xxx)! ⁵⁾ Cooling power sufficient even with optional internal braking resistor					

Table A.11 Technical data SO84.072 to SO84.210, liquid cooling

A.2.6 SO84.250 to SO84.450, liquid cooling

Designation	SO84.250	SO84.325	SO84.450
Technical data			
Output motor side ¹⁾			
Voltage	3-phase U_{Net}		
Rated current effective (I_N)	250 A	325 A	450 A
Peak current	see Table A.6		
Rotating field frequency	0 ... 400 Hz		
Output stage switching frequency	2, 4 kHz		
Input mains supply side			
Mains voltage	(3 x 230 V / 3 x 400 V / 3 x 460 V / 3 x 480 V) $\pm 10\%$		
Device connected load ¹⁾ (with mains choke)	173 kVA	225 kVA	310 kVA
Current ¹⁾ (with mains choke)	250 A	325 A	450 A
Asymmetry of the mains voltage	$\pm 3\%$ max.		
Frequency	50/60 Hz $\pm 10\%$		
Power loss at I_N ¹⁾	3960 W	4800 W	6750 W
¹⁾ Values related to a mains voltage of 3 x 400 V_{eff} and a switching frequency of 8 kHz ⁴⁾ Connection of an ext. braking resistor is not permitted for devices with int. braking resistor (version SO8x.xxx.xxxx.7xxx)! ⁵⁾ Cooling power sufficient even with optional internal braking resistor			

Table A.12 Technical data SO84.250 to SO84.450, liquid cooling

Designation	SO84.250	SO84.325	SO84.450
Technical data			
DC link			
Capacity	3600 μ F	5400 μ F	7200 μ F
Brake chopper switch-on treshold	820 V DC		
Minimum ohmic resistance of an externally installed braking resistor	3.2 Ω ⁴⁾	2.5 Ω ⁴⁾	1.7 Ω ⁴⁾
Brake chopper continuous power with external braking resistor	210 kW	269 kW	395 kW
Peak brake chopper chopper with external braking resistor	210 kW	269 kW	395 kW
Optional: internal braking resistor	3.3 Ω		
Brake chopper continuous power with internal braking resistor	5000 W		
Peak brake chopper chopper with internal braking resistor	204 kW		
Cooler data			
Coolant pressure (nom. value / max. value)	1 / 2 bar		
Coolant flow ⁵⁾ (nom. value / max. value)	11 / 13 l per min		
Feed coolant temperature	The coolant temperature can be between 5 °C and 40 °C. However, the coolant temperature should not be more than 10 °K below the ambient temperature, to avoid moisture condensation on the heat sink.		
¹⁾ Values related to a mains voltage of 3 x 400 V_{eff} and a switching frequency of 8 kHz ⁴⁾ Connection of an ext. braking resistor is not permitted for devices with int. braking resistor (version SO8x.xxx.xxxx.7xxx)! ⁵⁾ Cooling power sufficient even with optional internal braking resistor			

Table A.12 Technical data SO84.250 to SO84.450, liquid cooling

A.3 Connections for motor cable

Characteristic	BG1 + BG2	BG3 + BG4	BG5	BG6 + BG6a	
				90 - 110 A	143 - 170 A
Connectivity for cables (flexible with ferrules)	0.25 - 4 mm ² (AWG 24 - AWG 10) *)	0.75 - 16 mm ² (AWG 18 - AWG 6)	max. 25 mm ² (AWG 4)	35 - 95 mm ² (AWG 2 - AWG 4/0)	50 - 150 mm ² (AWG 3 - AWG 5/0)
Tightening torque (Nm)	0.7 - 0.8	1.7 - 1.8	2.5 - 4.5	15 - 20	25 - 30
recommended crimping tool	Phoenix CRIMPFOX 6	Phoenix CRIMPFOX 6 or 16 S	Phoenix CRIMPFOX or similar	-	-

*) Suitable for ferrules without plastic sleeve up to 6 mm²

Table A.13 Technical data terminals for motor cable BG1 to BG6a

Characteristic	BG7
Screws for ring terminal end	ZK-, ZK+, RB-, RB+: M10 L1-3, U, V, W: M12
Tightening torque (Nm)	Screws M10: 20-25 Screws M12: 25-30

Table A.14 Technical data for connecting bars for motor cable BG7

A.4 Current demand of control supply

Housing variant	Size	max. starting current	Continuous current
Wall mounting	BG1 - BG4	6 A	2 A
	BG5	7 A	2.5 A
	BG6 - BG6a	10 A	0 A (10 A) ¹⁾
Liquid cooling	BG3 - BG4	6 A	2 A
	BG5	7 A	2 A
	BG6 - BG6a	8 A	0 A (2 A) ¹⁾
	BG7	4 A	2 A

1) The value in brackets is valid as long as the voltage supply for the power section is switched off. Once the power section is supplied with voltage, an internal high-voltage switch-mode power supply will take over the supply for the control unit..

Table A.15 Current demand of control supply

A.5 Ambient conditions

Ambient conditions	ServoOne
Degree of protection	IP20 except the terminals (IP00)
Accident prevention instructions	according to local regulations (in Germany e.g. BGV A3)
Mounting height	up to 1000 m above sea level, higher than 1000 m above sea level with reduced power 1% per 100 m, max. 2000 m above sea level
Pollution severity	2
Type of installation	Built-in unit, only for vertical installation in a control cabinet with min. degree of protection IP4x, when using the safety function STO min. IP54.

Table A.16 Ambient conditions ServoOne

Climatic conditions		ServoOne
during transport	acc. to EN 61800-2, IEC 60721-3-2 class 2K3 ¹⁾	
	Temperature	-25 °C to +70 °C
	Relative air humidity	95% at max. +40 °C
during storage	acc. to EN 61800-2, IEC 60721-3-1 class 1K3 and 1K4 ²⁾	
	Temperature	-25 °C to +55 °C
	Relative air humidity	5 to 95%
during operation	acc. to EN 61800-2, IEC 60721-3-3 class 3K3 ³⁾	
	Air cooling	BG1 -10 °C to +45 °C (4 kHz) -10 °C to +40 °C (8, 12, 16 kHz)
		BG2 to BG4 -10 °C to +45 °C (4 kHz), up to 55 °C with power reduction (5% per °C) -10 °C to +40 °C (8, 12, 16 kHz), up to 55 °C with power reduction (4% per °C)
		BG5 to BG6a -10 °C to +45 °C (4 kHz) -10 °C to +40 °C (8, 12, 16 kHz), above up to 55 °C with power reduction (2% per °C)
		BG3 and BG4 -10 °C to +45 °C (4 kHz), up to 55 °C with power reduction (5% per °C) -10 °C to +40 °C (8, 12, 16 kHz), up to 55 °C with power reduction (4% per °C)
		BG5 to BG6a -10 °C to +45 °C (4, 8, 12, 16 kHz), up to 55 °C with power reduction (2% per °C)
	Liquid cooling	BG7 -10 °C to +40 °C (2, 4 kHz), up to 55 °C with power reduction (2% per °C)
		Relative air humidity

1) The absolute air humidity is limited to max. 60 g/m³. This means e.g. at 70 °C, that the relative humidity must only be max. 40%.

2) The absolute air humidity is limited to max. 29 g/m³. The maximum values for temperature and relative air humidity specified in the table must not occur at the same time.

3) The absolute air humidity is limited to max. 25 g/m³. This means, that the maximum values for temperature and relative air humidity specified in the table must not occur at the same time.

Table A.17 Climatic conditions ServoOne

Mechanical conditions		ServoOne	
Vibration limit during transport	acc. to EN 61800-2, IEC 60721-3-2 class 2M1		
	Frequency [Hz]	Amplitude [mm]	Acceleration [m/s²]
	2 ≤ f < 9	3.5	not applicable
	9 ≤ f < 200	not applicable	10
	200 ≤ f < 500	not applicable	15
Shock limit during transport	acc. to EN 61800-2, IEC 60721-2-2 class 2M1		
	Dropping height of packed device max. 0.25 m		
Vibration limits of system ¹⁾	acc. to EN 61800-2, IEC 60721-3-3 class 3M1		
	Frequency [Hz]	Amplitude [mm]	Acceleration [m/s²]
	2 ≤ f < 9	0.3	not applicable
	9 ≤ f < 200	not applicable	1

1) Note: The devices are solely intended for stationary use.

Table A.18 Mechanical conditions ServoOne



ATTENTION!

- **Control cabinet min. IP54 for STO**
According to EN ISO 13849-2 the control cabinet must have degree of protection IP54 or higher when using the safety function STO (Safe Torque OFF).
- **No continuous vibrations!**
The drive controllers must not be installed in areas where they would be permanently exposed to vibrations.

A.6 Mains filter

Details to the subject "Electromagnetic Compatibility" can be found in section 3.1 "Notes for installation" starting from page 17.

The following table shows the permissible motor cable lengths in accordance with the standard EN 61800-3.

Drive controller	4 kHz power stage cycle frequency		8 kHz power stage cycle frequency		12 kHz power stage cycle frequency		16 kHz power stage cycle frequency	
	Categorie							
	C3	C2	C3	C2	C3	C2	C3	C2
SO84.004 ¹⁾	40 m	20 m	40 m	15 m	40 m	10 m	40 m	8 m
SO84.006 ¹⁾	40 m	20 m	40 m	15 m	40 m	10 m	40 m	8 m
SO84.008 ¹⁾	40 m	20 m	40 m	15 m	40 m	10 m	40 m	10 m
SO84.012 ¹⁾	40 m	20 m	40 m	15 m	40 m	10 m	40 m	10 m
SO84.016 ¹⁾	40 m	10 m	40 m	10 m	40 m	10 m	40 m	10 m
SO84.020 ¹⁾	40 m	10 m	40 m	10 m	40 m	10 m	40 m	10 m
SO84.024 ¹⁾	40 m	10 m	40 m	10 m	40 m	10 m	40 m	10 m
SO84.032 ¹⁾	40 m	10 m	40 m	10 m	40 m	10 m	40 m	10 m
SO84.045 ^{2) 3)}	25 m	10 m	25 m	10 m	25 m	10 m	25 m	10 m
SO84.060 ^{2) 3)}	25 m	10 m	25 m	10 m	25 m	10 m	25 m	10 m
SO84.072 ^{2) 3)}	25 m	10 m	25 m	10 m	25 m	10 m	25 m	10 m
SO84.090 ^{2) 3)}	25 m	10 m	25 m	10 m	25 m	10 m	25 m	10 m
SO84.110 ^{2) 3)}	25 m	10 m	25 m	10 m	25 m	10 m	25 m	10 m
SO84.143 ^{2) 3)}	25 m	10 m	25 m	10 m	25 m	10 m	25 m	10 m

C3 = "Second environment" (industrial area)
C2 = "First environment" (residential area)
1) The motor shield terminal is not on the plate screen, but directly on the device terminals.
2) For compliance with the standard mains chokes ($uK = 4\%$ to 32 A / $uK = 2\%$ at 45 to 450 A) must be used
3) Compliance with the standard is only possible when using an external filter (no internal filter present)

Table A.19 Permissible motor cable length

Drive controller	4 kHz power stage cycle frequency		8 kHz power stage cycle frequency		12 kHz power stage cycle frequency		16 kHz power stage cycle frequency	
	Categorie							
	C3	C2	C3	C2	C3	C2	C3	C2
SO84.170 ^{2) 3)}	25 m	10 m	25 m	10 m	25 m	10 m	25 m	10 m
SO84.250 ^{2) 3)}	25 m	10 m	25 m	10 m	25 m	10 m	25 m	10 m
SO84.375 ^{2) 3)}	25 m	10 m	25 m	10 m	25 m	10 m	25 m	10 m
SO84.450 ^{2) 3)}	25 m	10 m	25 m	10 m	25 m	10 m	25 m	10 m

C3 = "Second environment" (industrial area)
C2 = "First environment" (residential area)
1) The motor shield terminal is not on the plate screen, but directly on the device terminals.
2) For compliance with the standard mains chokes ($uK = 4\%$ to 32 A / $uK = 2\%$ at 45 to 450 A) must be used
3) Compliance with the standard is only possible when using an external filter (no internal filter present)

Table A.19 Permissible motor cable length

A.7 Hydrological data for the liquid cooling



ATTENTION! The temperature of the cooling plate must not drop lower than 10 °C below the ambient temperature. Condensation will damage the device.



NOTE: The customer must ensure sufficient heat discharge from the water cooler. The coolant must be approved by LTi DRIVES.

Requirements	Limits
Coolant quality	Recommended: Drinking water + corrosion inhibitor (e.g. ethylene glycol) Not permitted are: Chloride ions (Cl ⁻ > 100 ppm) Calcium carbonate (CaCO ₃ > 160 ppm)
Pollution	The coolant must be as pure as possible, to prevent clogging of channels. With a suspended matter concentration of more than 15 mg/dm ³ continuous cleaning is recommended.
Coolant operating temperature	The coolant temperature can be between 5 °C and 40 °C. However, the coolant temperature should not be more than 10 °K below the ambient temperature, to avoid moisture condensation on the heat sink.
Cooler material	Aluminium
Recooling system ¹⁾	e.g.: Pfannenberg Rack 2400 (BG6, 6a), Pfannenberg EB 43 WT (BG7)

1) Rating for devices without internal braking resistor

Table A.20 Requirements on liquid cooling

A.8 Dynamic monitoring of the heat sink temperature

Should the coolant flow be interrupted or not start at all, the power stage may overheat. For this reason the drive controller is equipped with dynamic coolant temperature monitoring, which switches the drive controller off in case of overtemperature. The drive controller switches off at a heat sink temperature of 65 °C, irrespective of the temperature gradient.

A.9 UL-approbation

A.9.1 Measures to comply with the UL-approbation (UL 508C) BG1 to BG4

1. The devices must only be operated on networks of 1. overvoltage category III.
2. The devices can be used in networks with a maximum possible current of 5 kA 2. with phase symmetric current and a max. voltage of 480 V with network fusing acc. to table A.21.
3. The devices are designed for installation in 3. environments with pollution severity 2 acc. to EN 60664-1.
4. The integrated back-up fuse does not serve as protective device for branch lines. The protective device for branch lines must be designed according to the instructions of the manufacturer, the NEC regulations (National Electrical Code) and other locally valid standards.
5. Only UL-qualified device connecting cables (mains, motor and control cables) must be used:
 - use copper cables with a temperature resistance of min. 75 °C.
 - Required tightening torques for the terminals: see table A.21.
6. Maximum ambient air temperature: see table A.16.
7. An isolated voltage supply with a nominal voltage of 24 V DC is to be used for the relay output OSD04, the output from the supply is to be protected externally with a 4 A fuse as per UL 248.

Size	Device	Tightening torque mains and motor terminals	Tightening torque control terminals	Mains fuse / class
BG1	SO82.004	0.56 - 0.79 Nm	0.56 - 0.79 Nm	1 x 20 A / K5
	SO84.004	0.56 - 0.79 Nm	0.56 - 0.79 Nm	3 x 10 A / K5
	SO84.006	0.56 - 0.79 Nm	0.56 - 0.79 Nm	3 x 15 A / K5
BG2	SO84.008	0.56 - 0.79 Nm	0.56 - 0.79 Nm	3 x 20 A / RK5
	SO84.012	0.56 - 0.79 Nm	0.56 - 0.79 Nm	3 x 25 A / RK5
BG3	SO84.016	1.7 Nm	0.56 - 0.79 Nm	3 x 30 A / RK5
	SO84.020	1.7 Nm	0.56 - 0.79 Nm	3 x 40 A / RK5
BG4	SO84.024	1.7 Nm	0.56 - 0.79 Nm	3 x 50 A / K5
	SO84.032	1.7 Nm	0.56 - 0.79 Nm	3 x 60 A / K5

Table A.21 Tightening torques and mains fuse BG1 to BG4

A.9.2 Measures to comply with the UL-approbation (UL 508C) for BG5, 6 and 6a

- The devices must only be operated on networks of 1. overvoltage category III.
- The devices can be used in networks with a maximum possible current of 10 kA with phase symmetric current and a max. voltage of 480 V with network fusing acc. to table A.22.
- The devices are designed for installation in 3. environments with pollution severity 2 acc. to EN 60664-1.
- The integrated back-up fuse does not serve as protective device for branch lines. The protective device for branch lines must be designed according to the instructions of the manufacturer, the NEC regulations (National Electrical Code) and other locally valid standards.
- Only UL-approved circuit breakers and fuses of class RK1 may be used. For details on the fuse rating see table A.22.
- The device internal overload protection enables 2 times the rated device current for minimum 3 seconds.

- Only UL-qualified device connecting cables (mains, motor and control cables) must be used:
 - use copper cables with a temperature resistance of min. 75 °C.
 - Suitable tightening torques for terminals see table A.22
- If the device is to be operated with an enclosed 8. external braking resistor, this resistor must be separately protected against excessive temperatures.
- Maximum ambient air temperature: see table A.16.
- Technical boundary conditions for devices with 10. liquid cooling see table A.20.
- An isolated voltage supply with a nominal voltage of 24 V DC is to be used for the relay output OSD04, the output from the supply is to be protected externally with a 4 A fuse as per UL 248.

Size	Device	Tightening torque mains and motor terminals	Tightening torque control terminals	Mains fuse class RK 1
BG5	SO84.045			3 x 50 A
	SO84.060	2.5-4.5 Nm / 22-40 lb-in	2.5-4.5 Nm / 22-40 lb-in	3 x 80 A
	SO84.072			3 x 80 A
BG6	SO84.090	15-20 Nm / 133-177 lb-in	15-20 Nm / 133-177 lb-in	3 x 100 A
	SO84.110			3 x 125 A
BG6a	SO84.143	25-30 Nm / 221-265 lb-in	25-30 Nm / 221-265 lb-in	3 x 175 A
	SO84.170			3 x 200 A

Table A.22 Tightening torques and mains fuse BG5, BG6, BG6a

A.9.3 UL-approbation for BG7

An UL-approbation for BG7 is planned.

Glossary

Symbols

7-segment display.....	18, 19, 20, 21, 22, 23, 45, 51, 54. <i>see also</i> Display
2004/108/EC	10
2006/42/EC	10
2006/95/EC	10

A

Accident prevention instructions. <i>See</i> BGV A3	
Accident prevention measures.....	17
Air cooling. <i>See</i> Cooling: Air cooling	
ANSI Z 535	10
Auxiliary system	42

B

BGV A3	9, 68
Brake chopper	38, 62, 63, 64, 65, 66, 67
Brake drive.....	32. <i>See also</i> Motor: Motor brake
Braking power	39, 40
Braking resistor.....	18, 19, 21, 23, 38–40, 62–67, 71, 72
Button. <i>See</i> T1, T2 (buttons)	

C

C2. <i>see</i> residential area	
C3. <i>see</i> Industrial area	
Cable	
Cable cross-section	9, 17, 27, 30, 36, 37
Cable diameter	35, 37
Cable length.....	27, 34, 37
Cabel protection	26

Cable routing.....	17
Cable shield.....	17, 30
Cable type	17, 35
Encoder cable	33, 34
Motor cable.....	17, 36, 37, 38, 68
Motor cable length	57, 58, 60, 61
Resolver cable.....	34, 36, 38
Signal line.....	17
CANopen. <i>see</i> Field bus option	
Capable for energy chains.....	34, 37
Circulation currents.....	32
Climatic conditions	69
Crimping Tool	68
Commissioning.....	9, 10, 17, 18, 28, 33, 41, 42, 43, 54
Connections	16, 17, 18, 20, 22, 24, 27, 30, 40, 43, 68
Connected load. <i>see</i> Device connected load	
Continuous braking power. <i>see</i> Braking power	
Control cabinet.....	11, 17, 24, 34, 35, 68, 69
Control unit.....	45, 46
Controller	42, 43
Control supply	17, 19, 21, 23, 24, 26, 32, 41, 42, 45, 50, 68
Current carrying capacity	26, 27, 57, 58, 60, 61

D

D1, D2. <i>see</i> 7-segment display; <i>see also</i> Display	
Danger class	10
Device connection power.....	62–67
Device status display	45, 46
Diagnosis	31, 33, 45, 51
Digital outputs. <i>see</i> Outputs: Digital outputs	
Digital inputs. <i>see</i> Inputs: Digital inputs	
Dimensional drawing	13, 15

Dimensions	12, 14
DIN EN 954. <i>see</i> EN ISO 13849	
DIN EN 1050. <i>see</i> EN ISO 14121	
DIN VDE 0100.....	9
Display.....	46, 48, 50. <i>see also</i> 7-segment display
DriveManager	33, 36, 38, 41, 42, 43, 44, 48, 54

E

Electrical isolation concept	24, 25
EMC	
EMC compatible installation	11
EMC product standard. <i>see</i> EN 61800	
EMC directive. <i>see</i> 2004/108/EG	
Emergency OFF.....	10
EN 50014	10
EN 50018	10
EN 50178	26
EN 60204	10
EN 60664	11, 71, 72
EN 61000	27
EN 61800	17, 24, 26, 27, 29, 35, 36, 51, 69, 70
Encoder	18, 19, 21, 23, 33, 34, 35
EnDat	34, 35, 36
Encoder connection	33
Encoder cable. <i>see</i> Cable: Encoder cable	
Encoder type	34
HIPERFACE®.....	34, 35, 36
SinCos	34, 35, 36
SSI.....	34, 35, 36
EN ISO 13849	10, 11, 69
EN ISO 14121	10
ENPO	30, 31, 43
Environment	11, 29, 41, 70, 71, 72
Ambient conditions	11, 27, 68

Environment class	27
Ambient temperature	27, 36, 39, 57, 65, 66, 67, 71
Error	
Error code.....	51, 54
Error number	46, 47, 51
Fault current. <i>see</i> FI protective device	
EtherCAT. <i>see</i> Field bus option: EtherCAT	
Ethernet interface. <i>see</i> Service interface: Ethernet interface	
potentially explosive areas. <i>see</i> EN 50014; <i>see also</i> EN 50018	

F

Field bus option	49. <i>see also</i> Option 1
EtherCAT	33
Field bus address menu.....	49
SERCOS	33, 49
Firmware	2, 45, 50, 80
FI protective device	27

G

Grounding	
Ground connection.....	9
Grounding measures.....	17

H

Helpline	11, 17, 54. <i>see also</i> Support & Service
HIPERFACE®. <i>see</i> Encoder: HIPERFACE®	
Hydrological data	71. <i>see also</i> Cooling

I

I ² t.....	57, 58, 60, 61
IEC 364.....	9
IEC 60755.....	27
Industrial area	29, 70
Initial commissioning.....	41, 42

Inputs	
Analog inputs	31
Digital inputs	31
Installation	9, 11, 68
Mounting clearances	11, 12, 14
Mounting plate	11, 17
Intended use	10
Intermittent operation	57, 58, 60, 61
IP address menu	48
ISDSH	30, 31, 43

K

Klixon. <i>see</i> motor: motor temperature sensor: Klixon	
KTY. <i>See</i> Motor: Motor temperature sensor: KTY	
Cooling	11, 41
Air cooling	12, 13, 57, 58, 62, 63, 64, 69
Cooling	16
Coolin supply	11, 41, 60, 61, 71
Cooling circuit	16
Cooling air	11, 41
Liquid cooling	4, 11, 14–16, 20, 60, 61, 65–69, 71, 72

L

Layout	18, 20, 22
Leakage current	24
Liquid cooling. <i>see</i> Cooling: Liquid cooling	
Low voltage directive. <i>see</i> 2006/95/EG	
LSH motor. <i>See</i> Motor: LSH motor	
LST motor. <i>See</i> Motor: LST motor	

M

Machine directive. <i>See</i> 2006/42/EG	
Mains	

Network type	
IT network	27
TN network	27
TT network	27
Mains off	9, 17, 27, 40
Mains choke	11, 24, 27, 28, 29, 30, 62, 63, 64, 65, 66, 67
Mains filter	11, 28, 29, 30, 70
Mains fuse	27, 28, 72
Mains supply	17, 19, 21, 23, 24, 27–30, 42, 43
Mechanical conditions	69
Minimum distance	12, 14
MMC card/-Slot	19, 21, 23, 44–47, 50. <i>See also</i> X1
Motor	
LSH motor	34, 36, 37, 38, 42
LST motor	34, 36, 37, 42
Motor brake	19, 21, 23, 26, 32, 43
Motor cable. <i>See</i> Cable: Motor cable	
Motor choke	17
Motor connection	24, 36, 37
Motor contactor	17, 38
Motor dataset	42
Motor temperature sensor	
Klixon	35
KTY	35
PTC	24, 34–38, 62
Motor temperature monitoring	19, 21, 23
Motor winding	35, 36

N

Name plate	4, 19, 21, 23, 54
Neutral point	27

O

Option 1	18, 19, 20, 21, 22, 23, 33. <i>See also</i> Field bus option
Option 2	19, 21, 23, 33. <i>See also</i> X8

Order code	4, 34, 37
Outputs. <i>see also</i> Relay output	
Digital outputs.....	31, 38
Overvoltage category	27, 71, 72

P

Parameter setting.....	41, 42, 45
Parameter menu	46, 47
Peak braking power. <i>See</i> Braking power	
Peak current	57, 58, 60–67
PELV. <i>See</i> Protective Extra Low Voltage	
PE (Protective Earth). <i>See also</i> Earthing lead	
PE bar.....	17, 24
PE terminal	9, 17, 18, 19, 21, 23, 24, 72. <i>See also</i> PE (Protective Earth)
Pictogram	5
Pollution severity.....	11, 68, 71, 72
Pre-charging	23, 29, 30
Precharging connection	30
Precharging contactor.....	30
Precharging resistors.....	30
PROFIBUS. <i>see</i> Fieldbus option	
PTC. <i>see</i> Motor: Motor temperature sensor: PTC	

Q

Qualification	9
---------------------	---

R

Rated current.....	4, 57, 58, 60, 61, 62, 63, 64, 65, 66, 67
Relay.....	17, 30, 31, 32
Relay outputs.....	31

Residential area	29, 70
Resolver	19, 21, 23, 34, 35, 38. <i>see also</i> encoder
Responsibility.....	10
Restart	49
Restart inhibit	31
Riscs	10
Rotating field frequency.....	57, 58, 60, 61, 62, 63, 64, 65, 66, 67

S

Safety	9, 10
Device protection.....	27
Safety function	11, 41, 43, 55, 68, 69
Safety notes.....	9, 10, 41
Protective extra-low voltage.....	24
Safety technology.....	4
Safety low voltage	24
Save.....	46, 49, 54
SERCOS. <i>See</i> Field bus option: SERCOS	
Serial number	4, 29, 54
Service. <i>See</i> Support & Service	
Service interface	
Ethernet Interface.....	19, 21, 23, 33
USB Interface.....	33
Shielding	
Cable shield. <i>See</i> Cable: Cable shield	
Shielding measures	17
Signal line. <i>see</i> Cable: Signal line	
SinCos. <i>see</i> Encoder: SinCos	
SSI. <i>see</i> Encoder: SSI	
STO	11, 31, 41, 43, 51, 55, 68, 69

Stop category	10
Subnet mask	45, 48
Supply voltage	35, 45
Support & Service	54. <i>see also</i> Helpline
Switching on sequence	43

T

T1, T2 (buttons)	18–23, 45, 46
Technical data	9, 27, 34, 37, 40, 62–68
Technology options. <i>see</i> Option 2	
Terminals	19, 21, 23, 30, 72. <i>See also</i> X4
Terminal diagram	5, 19, 21, 23, 30
Tightening torque	68
TN-network. <i>see</i> Mains: Network type: TN-network	
TT-network. <i>see</i> Mains: Network type: TT-network	

U

UL approbation	71, 72
Update. <i>See</i> Firmware	
USB Interface. <i>See</i> Service interface: USB Interface	

V

VDE 0113. <i>See</i> EN 60204	
Vibration	11, 69
Scope of supply (cooling)	11, 16, 65, 66, 67

W

Wall mounting	20, 68
Warning symbols	5, 10. <i>See also</i> Pictogram

X

X1	18–23, 45. <i>See also</i> MMC card/Slot
X2	18–23, 33. <i>See also</i> Service interface: USB Interface
X3	18–23, 33. <i>See also</i> Service interface: Ethernet Interface
X4	18–23, 30, 31, 43. <i>See also</i> Terminals
X5	18–25, 36, 43. <i>See also</i> Motor: Motor temperature sensor
X6	18–23, 34–36, 43. <i>See also</i> Resolver
X7	18–23, 34–36. <i>See also</i> Encoder
X8	18–23. <i>See also</i> Option 2
X9	17–21, 26, 32, 51. <i>See also</i> T1, T2 (button)
X10. <i>See</i> X9	
X11	17–23, 26. <i>See also</i> Net: Control supply
X12	17–23, 36, 47
X13	18, 19, 32
X20	20, 21, 32
X44	17, 22, 23, 26, 30, 32
X45	22, 23, 30. <i>See also</i> Pre-charging

Y

Year of production	4
--------------------------	---

Z

Zero pulse	35
------------------	----



LTI DRIVES GmbH

Gewerbestraße 5-9
35633 Lahnau
Germany
Fon +49 6441 966-0
Fax +49 6441 966-137
www.lt-i.com
info@lt-i.com

Technical alterations reserved.

The contents of our documentation have been compiled with greatest care and in compliance with our present status of information.

Nevertheless we would like to point out that this document cannot always be updated parallel to the technical further development of our products.

Information and specifications may be changed at any time. For information on the latest version please refer to <http://drives.lt-i.com>.

Id.-No.: 1100.20B.6-00

Status: 09/2011

Valid from firmware version: V2.20-01

The German version is the original version of the operation manual.